



S8901-54XC

Data Center ToR/Leaf Switch

Hardware Installation Guide



R1.1



Table of Contents

1	Overview	1
2	Preparation	2
2.1	Installation Tools	2
2.2	Installation Environment Requirements	3
2.3	Preparation Check List.....	4
3	Package Contents	5
3.1	Accessory List	5
3.2	Component Physical Information.....	6
4	Identifying Your System	7
4.1	S8901-54XC System Overview.....	7
4.2	DC Version PSU Overview	8
4.3	AC Version PSU Overview.....	9
4.4	Fan Overview.....	10
4.5	Port Overview.....	10
5	Rack Mounting	11
6	Installing Fan Modules	13
7	Installing Power Supply Units	14
8	Grounding the Switch	16
9	Connecting Power	18
9.1	DC Version	18
9.2	AC Version	19
10	Verifying System Operation	20
10.1	Front Panel LED	20
10.2	PSU FRU LED.....	21
10.3	Fan FRU LED.....	21
10.4	Management Port LED	21
11	Initial System Setup	22
12	Cable Connections	23
12.1	Connecting the USB Cable.....	23
12.2	Connecting the OOB Management Cables.....	23
12.3	Connecting the Transceivers	24
13	Cautions and Regulatory Compliance Statements	25



1 Overview

The UfiSpace S8901-54XC is a high-performance, versatile open networking white box switch that is designed to provide data center the needed connectivity required from different servers and devices.

With a small form factor and high-density configurations, the S8901-54XC switch is a white box switch that can be positioned as a ToR (Top-of-Rack) or leaf switch to enable versatile connectivity and traffic management. It comes with redundant, hot swappable components for convenience, increased availability, reliability and lower costs of maintenance.

This document describes the hardware installation process for S8901-54XC.



2 Preparation

2.1 Installation Tools



Screwdriver (Phillips head #2)

Phillips #2 Screwdriver

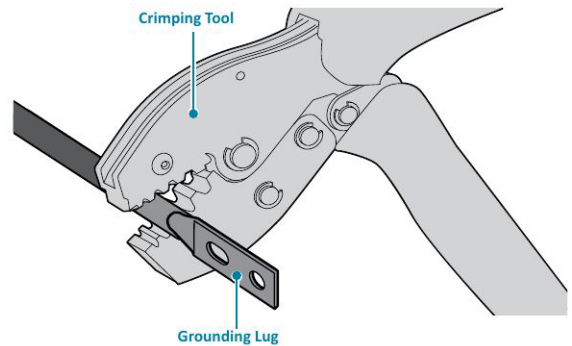

Crimping tool

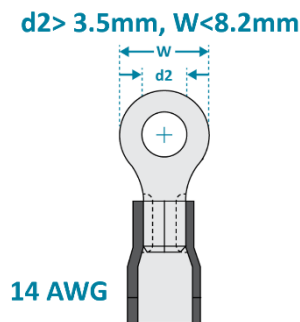

14-AWG wire with ring terminal for DC power supply

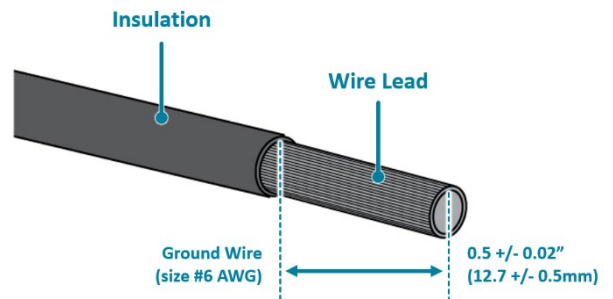

6-AWG wire for grounding



Wire-stripping tools for stripping 6-AWG copper wire

Console cable

- PC with terminal emulation software. Refer to the "Initial System Setup" section for details.
 - Baud rate: 115200 bps
 - Data bits: 8
 - Parity: None
 - Stop bits: 1
 - Flow control: None

2.2 Installation Environment Requirements

- Power Reserve: The S8901-54XC power supply is available with:
 1. **DC Version:** 1+1 active-active -36 to -75V DC power supply field replaceable unit or;
 2. **AC Version:** 1+1 active-active 100 to 240V AC power supply field replaceable unit.

To ensure the active-active feed power design functions properly, a field with dual power circuit is recommend with a reserve of at least 450 watts on each power circuit.

- Space Clearance: The S8901-54XC width is 17.32 inches (44.0cm) and shipped with a rack mount brackets suitable for 19 inch (43.8cm) wide racks. The depth of the S8901-54XC chassis is 17.32 inches (44cm) without the field replaceable units (FRUs) and comes with adjustable mounting rails suitable for rack depths of 22 inches (55.9cm) to 33 inches (83.8cm). The handle for the fan units will extend outwards by 1 inch (2.5cm) and the handle for the power supplies will extend outwards by 1.5 inches (3.8cm). Therefore, to accommodate the fan and power supply handles, a minimum space clearance of 6 inches (15.24cm) is needed at the back of the S8901-54XC. A total minimum reserve depth of 23.32 inches (59.23cm) is required.

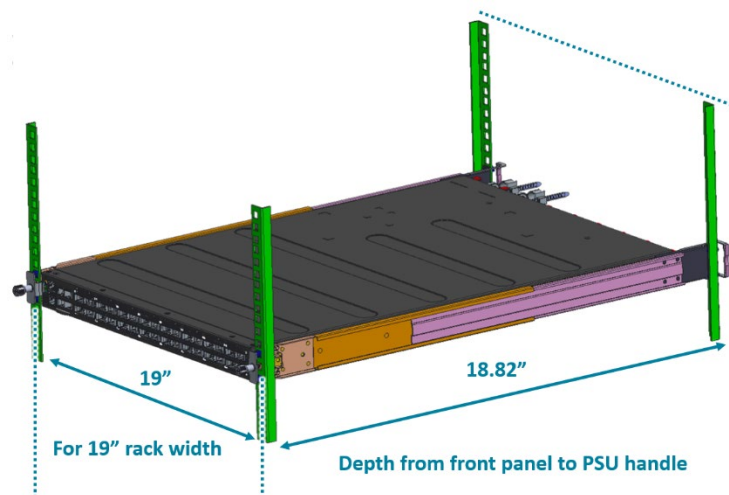

Figure 1.

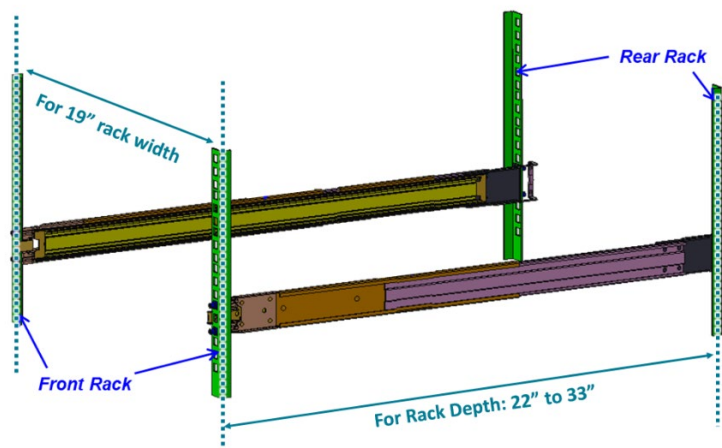

Figure 2.

- Cooling: The S8901-54XC has two options for airflow direction. There is a back-to-front option (Figure 3. Left) and a front-to-back option (Figure 3. Right). Make sure the equipment on the same rack have the same airflow direction.

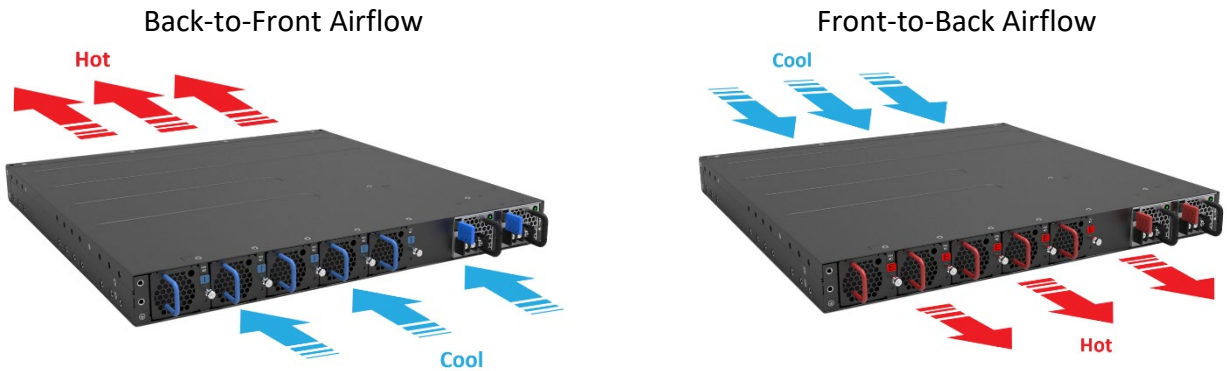

Figure 3.

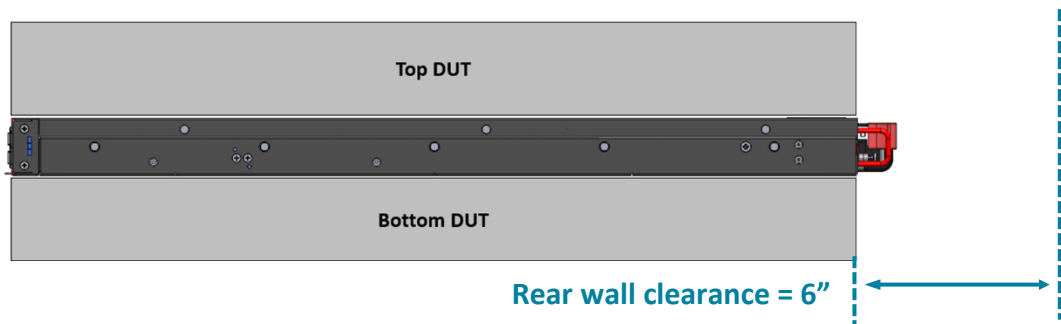

Figure 4.

2.3 Preparation Check List

Task	Check	Date
Power voltage and electric current requirement DC version: -36 to -75V DC, 16A maximum x2 or; AC version: 100 to 240V, 6A maximum x2		
Installation spacing requirement: S8901-54XC spacing requires a height of 1RU (1.72"/4.5cm), a width of 19" (48cm) and a depth of 17.32 inches (44cm)		
Thermal requirement S8901-54XC working temperature is 0°C to 45°C (32°F to 113°F)		
Installation tools required #2 Phillips Screwdriver, 6-AWG wire stripper, and crimping tool		
Accessories required PC with terminal emulation software, console cable, 14-AWG wire with ring terminal for power, 6-AWG wire for grounding		



3 Package Contents

3.1 Accessory List

Item	Description	Spec. & Dimensions	Qty.	Weight
1	Grounding kit for system	1 x Grounding Lug (#6 AWG) 1.14" x 1.47" x 0.49" (29 x 37.5 x 12.5mm) 2 x Screw: M4*L8.0mm 2 x M4 Lock Washers	1 set	0.037lb (17.0g)/set
2	Rack Mount Bracket	2.56" x 1.69" x 0.79" (19" width rack) (65x 43 x 20mm)	2 pcs	0.27lb (124g)/2pcs (0.14lb (62g)/pcs)
3	Screw Kit (for Rack Mount Bracket)	8 x Screws M4.0*L6.5mm	1 set	0.02lb (7g)/set
4	Adjustable Mounting Rail (for 4 posts)	16.02" x 1.69" x 0.83" (406.8 x 43 x 21mm) (for 22" to 33" rack depth)	2 sets	1.39lb (630g)/2 set (0.69lb (315g)/set)
5	Screw Kit (for Adjustable Mounting Rail)	8 x Screws M4.0*L6.5mm	1 set	0.02lb (7g)/set
6	Power Cord (AC Version only)	72.05" (1830mm)	2 pcs	1.43lb (650g)/2pcs 0.72lb (325g)/pcs
7	USB 3.0 cable	7.87" (200mm)	1 pcs	0.038lb (17.2g)/pcs
8	RJ45 to DB9 Female Cable	95.98" (2438mm)	1 pcs	0.23lb (105g)/pcs

3.2 Component Physical Information

Specification	Item	Description
Weight	Total package contents	34.17lbs (15.50kg)
	Chassis without FRU	19.18lbs (8.7kg)
	Power Supply Unit (PSU)	DC PSU: 2.2lbs (1.0kg) AC PSU: 2.6lbs (1.2kg)
	Fan module	0.41lbs (185g)
	Grounding lug kit	0.037lbs (17g)
	Adjustable mounting rail	0.69lbs (315g)
	USB 3.0 cable	0.04lbs (17.2g)
	AC power cord (AC version only)	0.72lbs (325g)
	RJ45 to DB9 female cable	0.23lbs (105g)
Dimension	S8901-54XC (W x D x H)	17.32" x 17.32" x 1.72" (440 x 440 x 43.8mm)
	PSU (W x D x H)	1.99" x 8.30" x 1.57" (50.5 x 211 x 40mm)
	Fan module (W x D x H)	2.03" x 1.66" x 2.28" (51.5 x 42.2 x 57.8mm)



4 Identifying Your System

4.1 S8901-54XC System Overview

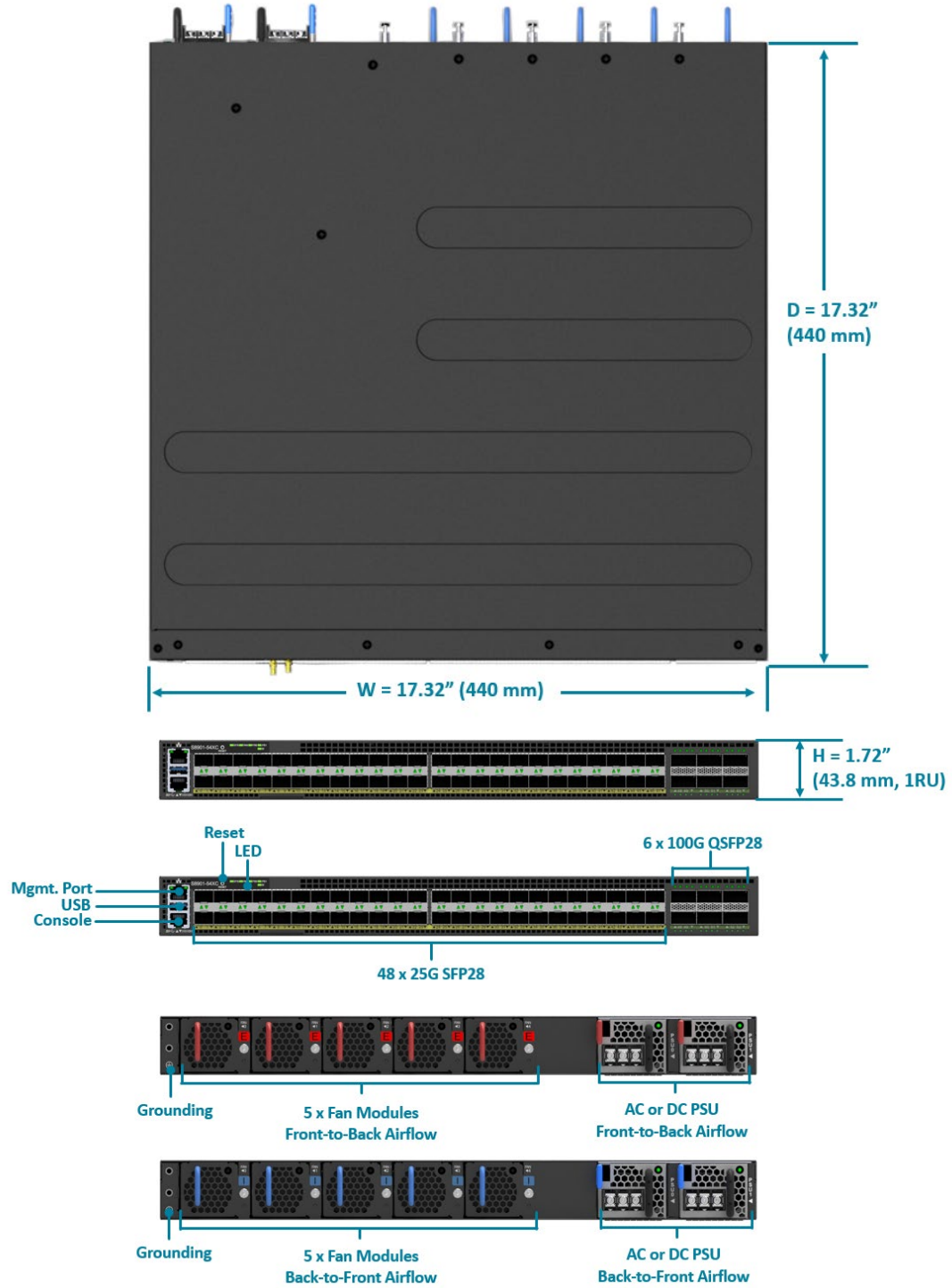

Figure 5.

4.2 DC Version PSU Overview

1+1, hot swappable power supply unit (PSU) field replaceable unit (FRU). There are two types of DC PSUs. The picture on the left is the DC PSU with back-to-front airflow, identified with a blue latch. The picture on the right is the DC PSU for front-to-back airflow, identified with a red latch.

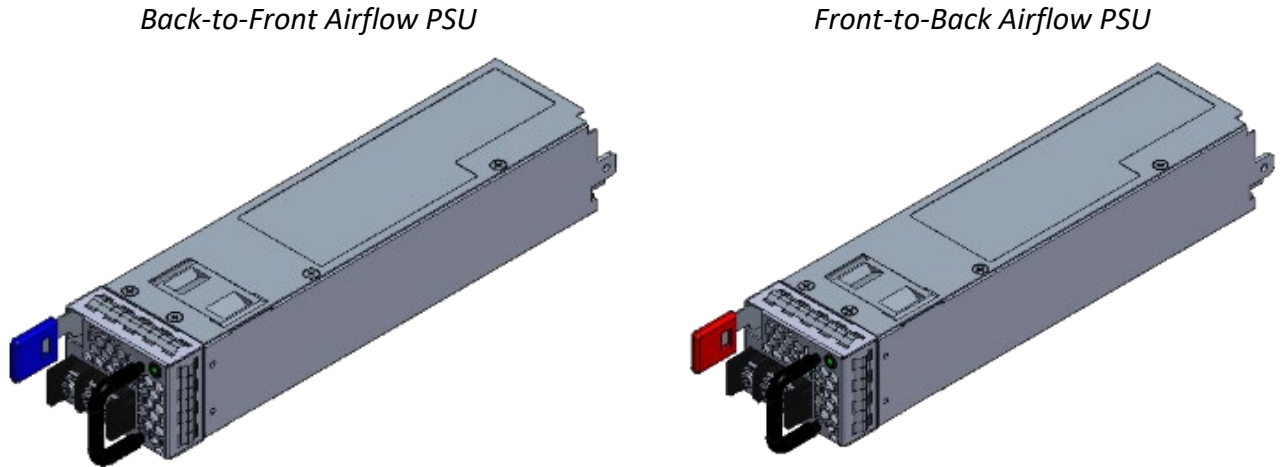
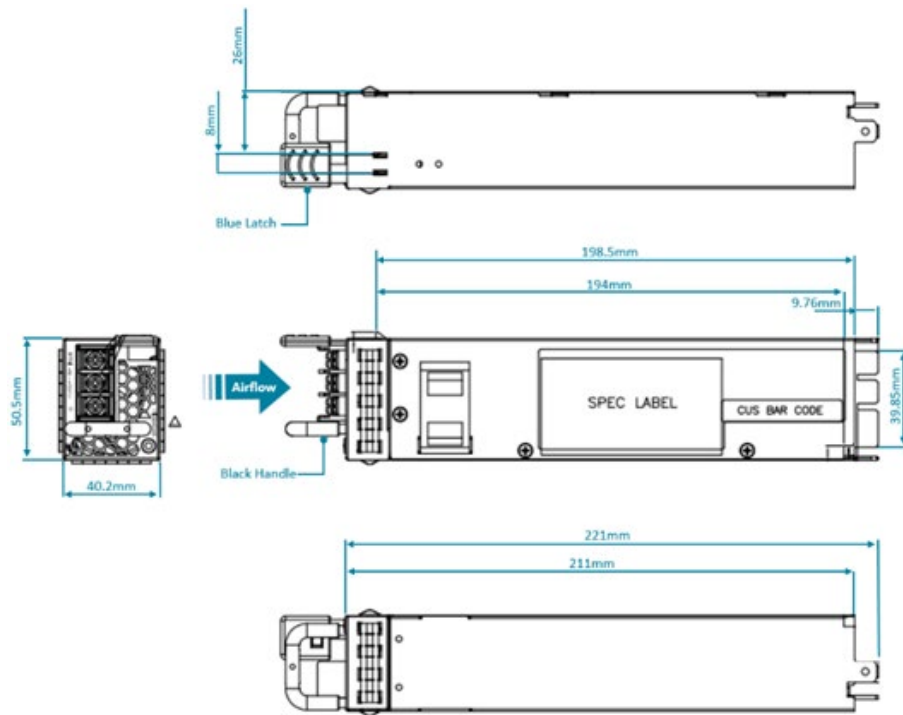

Figure 6.

The DC power supply units are the same size for both back-to-front airflow and front-to-back airflow. Therefore, only the dimensions for back-to-front airflow PSU will be provided in the figure below.



(Back-to-Front Airflow PSU)

Figure 7.

4.3 AC Version PSU Overview

1+1, hot swappable power supply unit (PSU) field replaceable unit (FRU). There are two types of AC PSUs. The picture on the left is the AC PSU with back-to-front airflow, identified with a blue latch. The picture on the right is the AC PSU for front-to-back airflow, identified with a red latch.

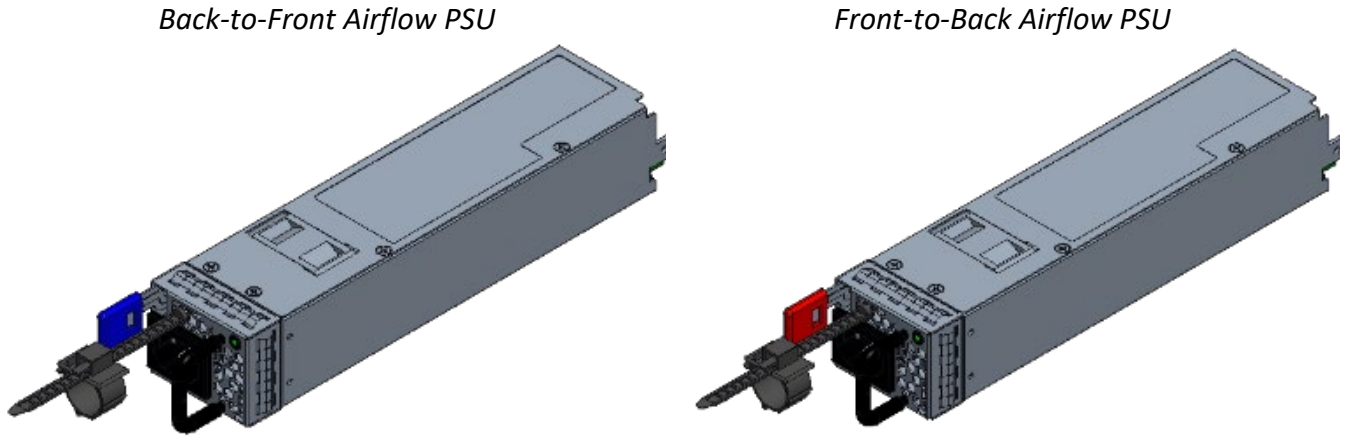
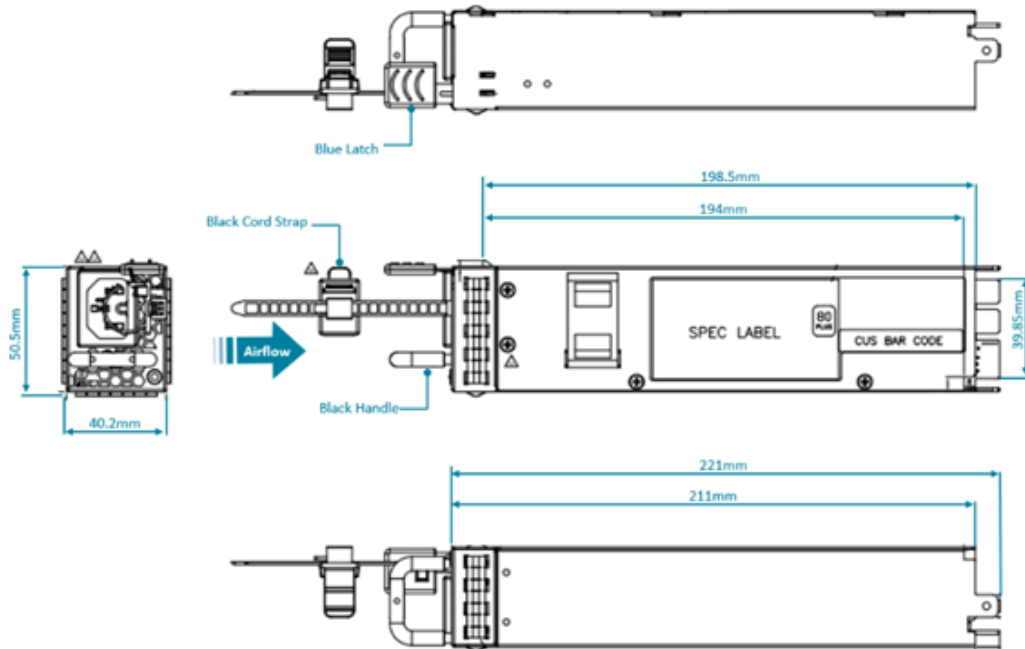

Figure 8.

The AC power supply units are the same size for both back-to-front airflow and front-to-back airflow. Therefore, only the dimensions for back-to-front airflow PSU will be provided in the figure below.



(Back-to-Front Airflow PSU)

Figure 9.

4.4 Fan Overview

4+1, hot swappable fan field replaceable unit (FRU). There are two types of fans, shown in the figure below. The top picture is for fans with back-to-front airflow, identified with a blue handle. The picture on the bottom is for the fans with front-to-back airflow, identified with a red handle.



(Back-to-Front Airflow Fans)



(Front-to-Back Airflow Fans)

Figure 10.

4.5 Port Overview

Port ID	Form Factor	Maximum Support Distance	Support Speed
0 ~ 47	SFP28	80km (49.7mi)	1/10/25G
48~53	QSFP28	80km (49.7mi)	40/100G



Figure 11.



5 Rack Mounting



Caution

It is recommended that installation be done by two trained professionals. One individual should hold the equipment in position on the rack while the other secures it in place.



Note

Illustrations are for reference purposes only. Actual equipment and scenario may differ. Screws for rack posts not included.

1. Secure the rack mount brackets onto the switch.
Align the rack mount brackets with the holes provided on the both sides of the case and secure the brackets using the 8 M4.0*L6.5mm screws provided with the package.

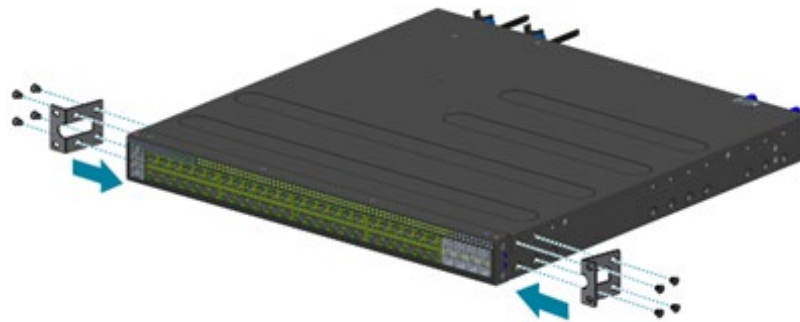

Figure 12.

There are multiple locations where rack mount brackets may be secured to the switch. The figure below shows the various locations for securing the rack mount brackets.

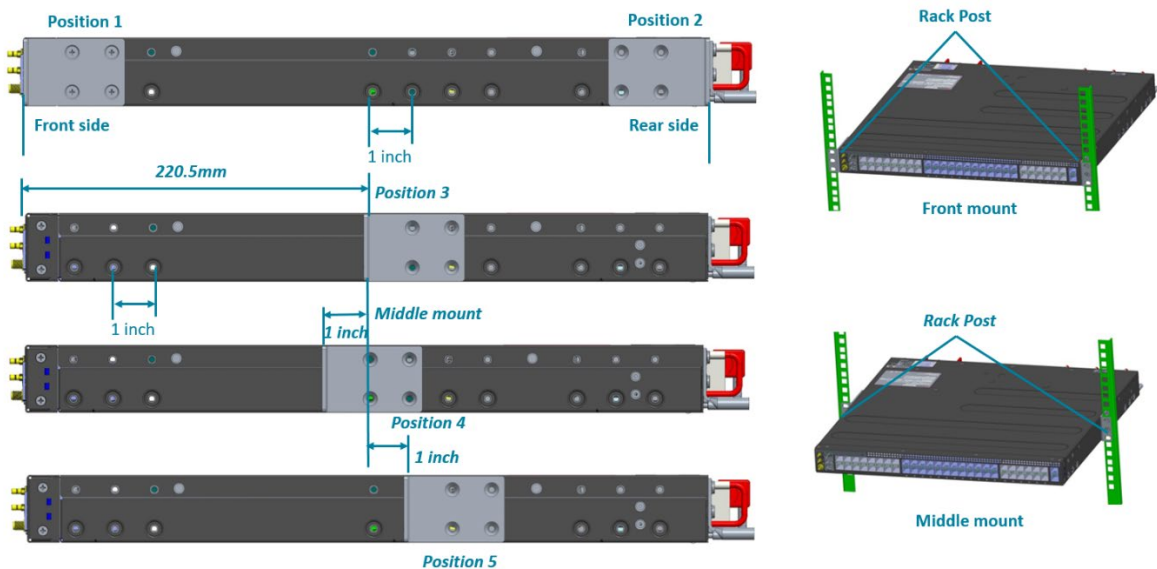

Figure 13.

2. Secure the switch onto the rack posts.
Mark the location on both posts to ensure it is leveled before securing the switch onto the rack. (See Figure Below).

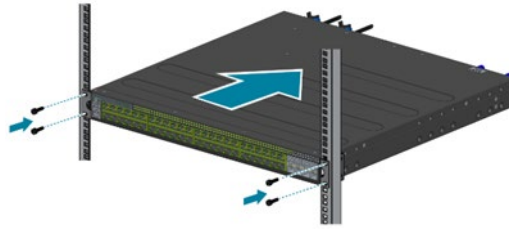

Figure 14.

For a 4 post rack, first secure the adjustable mounting rail to the back of the switch using the M4.0*L6.5mm screws provided in the package. Then secure the adjustable mounting rail to the rack posts. (See Figure Below).

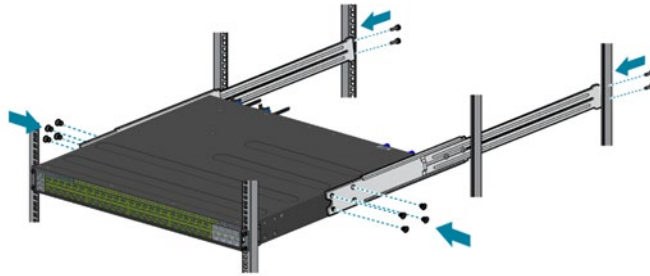

Figure 15.



6 Installing Fan Modules

The fan modules are hot swappable field replaceable units (FRUs), which can be replaced while the switch is operating as long as all the remaining modules are installed and in operation. The fans come pre-installed and the following steps are instructions on how to install a new fan module.

1. Loosen the captive screw located on the fan module.

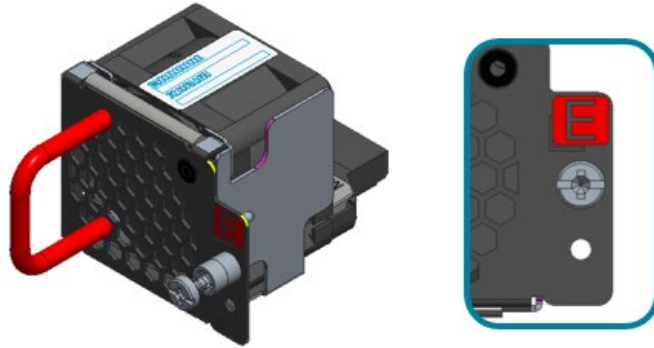

Figure 16.

2. Grip the fan's handle and firmly pull it out of the fan bay.

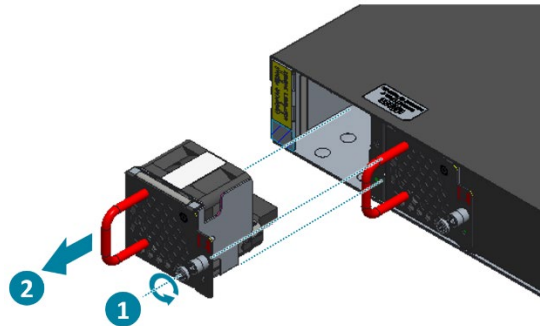

Figure 17.

3. Align the new fan module with the fan bay.
4. Carefully slide the new fan module into the fan bay and gently push until it is flush with the case.
5. Secure the captive screw on the fan module to lock the fan in place.

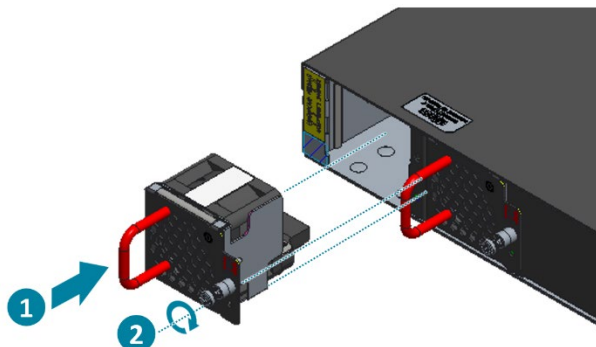

Figure 18.



7 Installing Power Supply Units

The power supply unit (PSU) is a hot swappable field replaceable unit (FRU) and can be replaced while the switch is operating as long as the remaining (second) PSU is installed and in operation. The PSUs comes pre-installed and the following are instructions on how to install a new PSU. The process for removing and installing the PSUs are the same for all models.

DC:

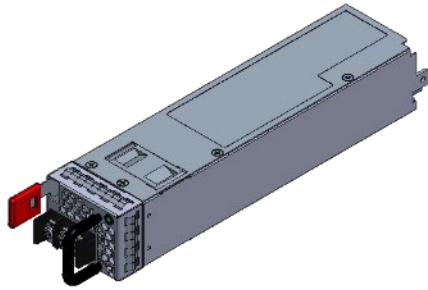

AC:

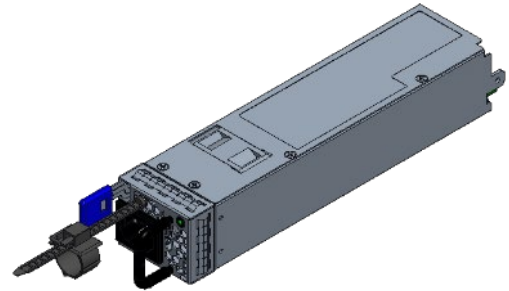

Figure 19.



Shock hazard!

For safety, please disconnect all power inputs from the power supply unit before servicing the switch.

1. Locate the release tab on the PSU. Then press and hold down the release tab to unlock the PSU from the power bay.
2. While holding down the release tab, grip the PSU's handle and firmly pull it out of the power bay.

DC Version:

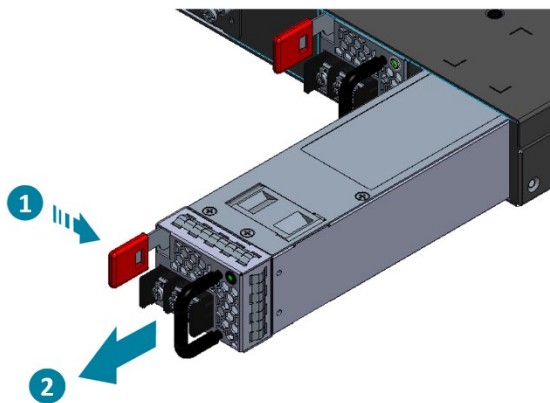

AC Version:

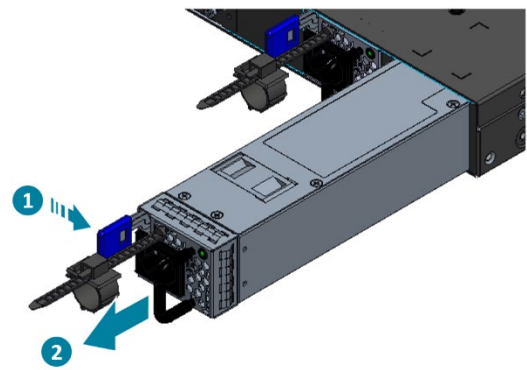

Figure 20.

3. Align the new PSU with the power bay, ensuring the PSU's power connector is in the correct position.

- Carefully slide the new PSU into the power bay and gently push until it is flush with the case.
- An audible click will be heard when the PSU is installed correctly. The PSU will not go in all the way if it is in the wrong direction.



Note

Illustrations are for reference purposes only. Actual PSU position may differ.

DC Version:

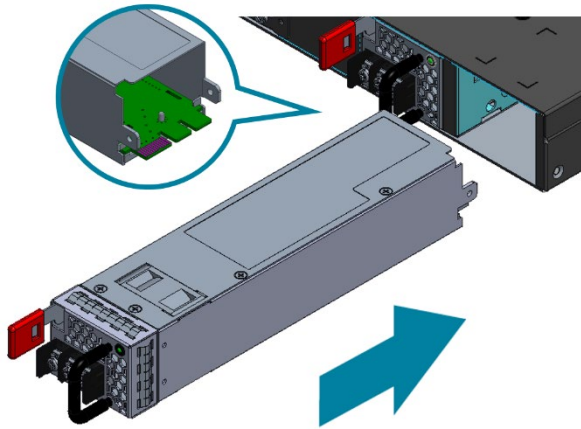

AC Version:

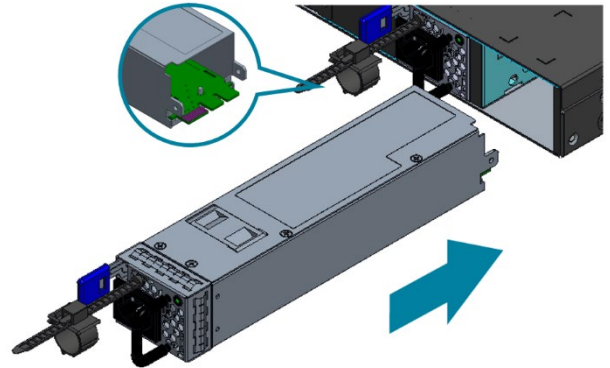

Figure 21.



8 Grounding the Switch

It is recommended that equipment changes be done on a grounded rack system. This will reduce or prevent the risk of shock hazards, equipment damage, and potential of data corruption.

The switch can be grounded from the switch's case and/or the power supply units (PSUs). When grounding the PSUs, ensure that both PSUs are grounded at the same time in case one of them is removed. A grounding lug and M4 screws and washers are provided with the package contents, however, the grounding wire is not included. For convenience, there are two locations on the case in which the grounding lug may be fixed.

The following instructions are for grounding the switch.



This equipment must be grounded. Do not defeat the ground conductor or operate the equipment without correctly grounding the equipment. If there is any uncertainty about the integrity of the equipment's grounding, please contact the electrical inspection authority or a certified electrician.

1. Before grounding the switch, ensure that the rack is properly grounded and in compliance with local regulatory guidelines. Ensure that there is nothing that can obstruct the connection for grounding and remove any paint or materials that may prevent good grounding contact.
2. Strip the insulation from a size #6 AWG grounding wire (not provided within the package contents), leaving 0.5" +/- 0.02" (12.7mm +/- 0.5mm) of exposed grounding wire.
3. Insert the exposed grounding wire all the way into the hole of the grounding lug (provided with package contents).
4. Using a crimping tool, firmly secure the grounding wire to the grounding lug.

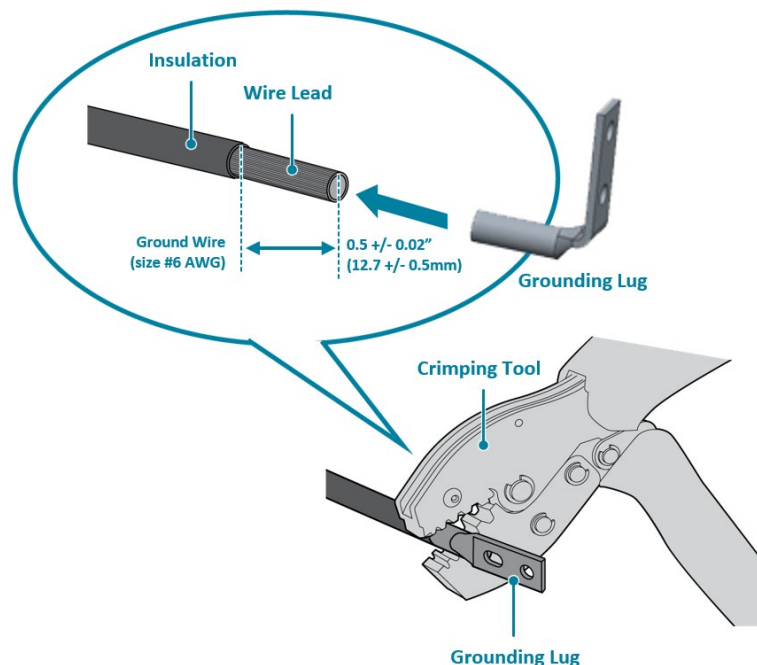

Figure 22.

5. Locate the designated location for securing the grounding lug, which is located on the side of the switch and remove the protective label.

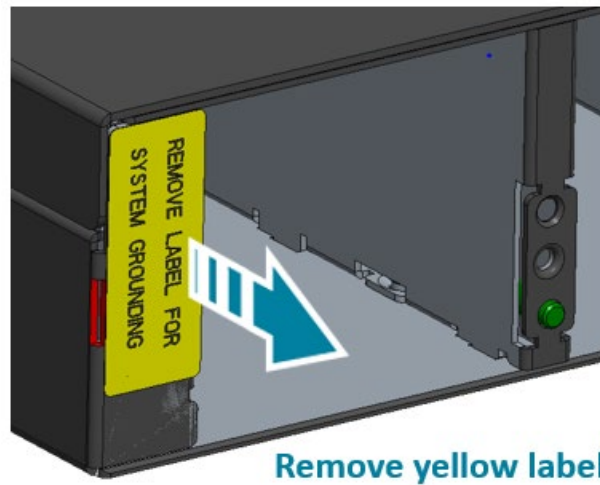

Figure 23.

6. Using 2 M4 screws and 2 washers (provided with the package contents), firmly lock the grounding lug to either of the designated grounding locations on the switch.

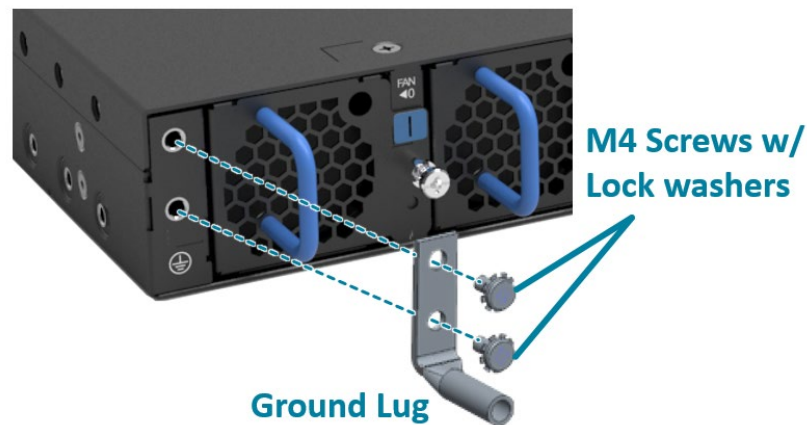

Figure 24.



9 Connecting Power

9.1 DC Version

1. Ensure there is enough power to supply the system.
The maximum system power consumption is 220.3 watts. It is recommended to ensure that enough power is reserved from the power distribution system before installation. Also, please ensure that both PSUs have been properly installed before powering up the equipment, as the S8901-54XC is designed to support 1 + 1 power redundancy.
2. Attach the power cable.
Locate the DC power screw-type terminal block on the DC PSU. Attach the UL 1015, 14 AWG DC power cable (not provided within the package contents) to the DC inlet connector on the PSU.



Dangerous voltage!

- Must be powered off before removing!
- Verify that all electrical connections are grounded before powering on
- The DC power source must be reliably grounded

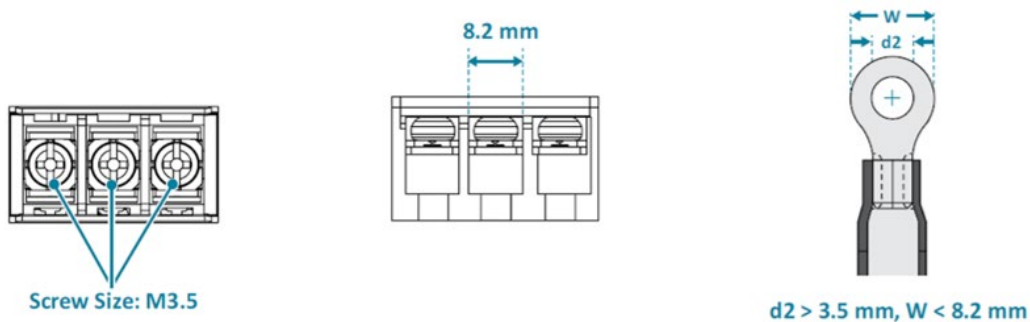

Figure 25.

3. Tighten the screws to the specified torque.
Tighten the screws to a torque value of 7.0+/-0.5kgf.cm. If the torque is not enough, the lug will not be secure and may cause malfunctions. If the torque is too much, the terminal block or lug may be damaged.

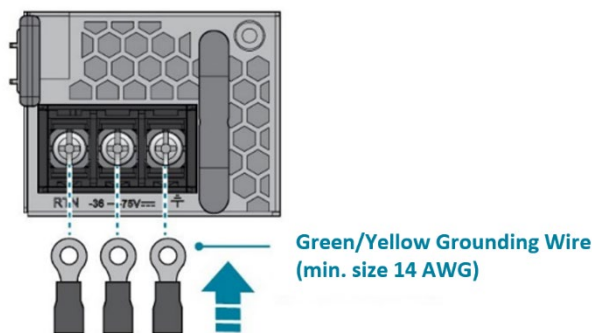

Figure 26.

4. Feed DC power into the system.
The PSU will immediately output 12V and 5VSB to the system when a -36V to -75V DC power source is applied. The PSU has a built in 20 amperes, fast acting fuse based on the PSU maximum capacity, which will act as a second tier system protection in case the power distribution unit's fuse is not functioning.
5. Verify that the power supply is operating.
If connected correctly, when turned on, the LED on the PSU will light up with a Green color designating normal operation.

9.2 AC Version

1. Ensure there is enough power to supply the system.
The maximum system power consumption is 220.3 watts with an input voltage of 100-240V AC. It is recommended to ensure that enough power is reserved from the power distribution system before installation. Also, please ensure that both PSUs have been properly installed before powering up the equipment, as the S8901-54XC is designed to support 1 + 1 power redundancy.
2. Attach the power cable.
Plug the power cord into the AC PSU and secure it tightly.
3. Verify that the power supply is operating.
If connected correctly, when turned on, the LED on the PSU will light up with a Green color designating normal operation.

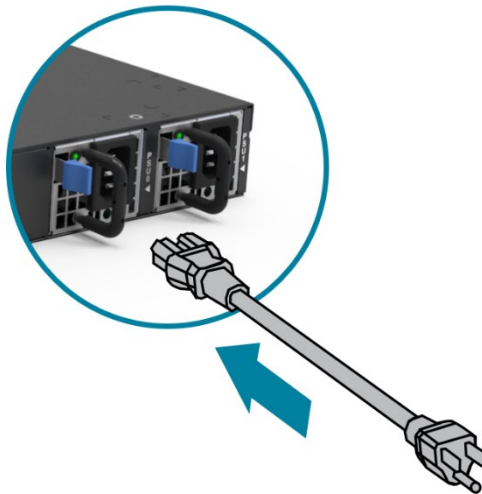

Figure 27.



10 Verifying System Operation

10.1 Front Panel LED

Verify basic operations by checking the system LEDs located on the front panel. When operating normally, the SYS, FAN, and PSU LEDs should all display green.

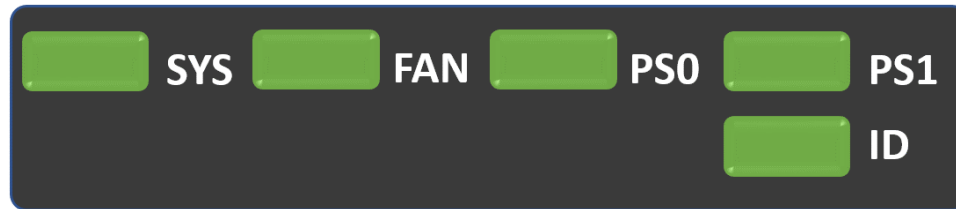

Figure 28.

LED Condition	Equipment Status
SYS	
Off	No power
Solid Green	Host CPU/BMC boot complete
Solid Amber	Power is up but Host CPU boot failed
FAN	
Off	Fans are not initialized
Solid Green	All Fans are work normal
Blinking Amber	Fan fail: one or more Fans need service
PS0	
Off	No power
Solid Green	PSU0 working normal
Blinking Amber	PSU0 fail (PSU0 needs service)
PS1	
Off	No power
Solid Green	PSU1 working normal
Blinking Amber	PSU1 fail (PSU1 needs service)
ID	
Off	No Power
Blinking Blue	Beacon feature is enabled on the switch

10.2 PSU FRU LED

Additional information about PSU status can be obtained by the LEDs located on the PSU itself.

LED Condition	Equipment Status
Off	No input power to all power supplies.
Green	Output ON and OK
Blinking Green (1/sec)	PSU standby state input power present / Only +5VSB on.
Blinking Green (2/sec)	Power supply firmware updating (Boot-loader mode).
Red	Power supply critical event causing a shutdown, failure, over current, short circuit, over voltage, fan failure, and/or over temperature.
Blinking Red (1/sec)	DC power cord unplugged or DC power lost with a second power supply in parallel still with DC input power. Power supply DC present, 5VSB and 12V off via on/off control from system.
Blinking between Green and Red	Power supply warning events where the power supply continues to operate; high temp, high power, high current, and/or slow fan.

10.3 Fan FRU LED

LED Condition	Equipment Status
Off	No input power
Solid Green	Fan is functioning normal
Blinking Amber	Fan is abnormal, service is required

10.4 Management Port LED

LED Condition	Equipment Status
Left LED	
Off	No power
Solid Green	1G link-up
Blinking Green	1G TX/RX activity
Right LED	
Off	No power
Solid Amber	10M/100M link-up
Blinking Amber	10M/100M TX/RX activity



11 Initial System Setup

Establishing a first-time serial connection.

To assign an IP address, you must have access to the command line interface (CLI). The CLI is a text-based interface that can be accessed through a direct serial connection to the device.

Access the CLI by connecting to the console port. After you assign an IP address, you can access the system through Telnet or SSH by Putty, TeraTerm or HyperTerminal.

Perform the following steps to access the device through a serial connection:

1. Connect the console cable.
 - The console can be connected using the RJ45 port labelled IOIO.
 - To connect to console, plug a RJ45 serial cable into the console port and connect the other end to the computer. Cable types may vary depending on the model.

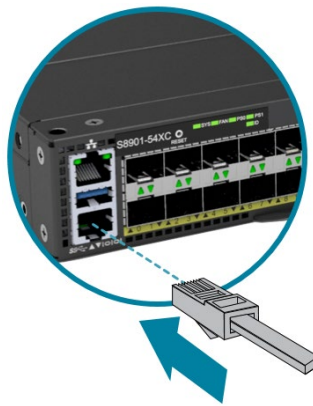

Figure 29.

2. Check for serial control availability.
Disable any serial communication programs running on the computer such as synchronization programs to prevent interference.
3. Launch a terminal emulator.
Open a terminal emulator application such as HyperTerminal (Windows PC), Putty or TeraTerm and configure the application. The following settings are for a Windows environment (other operating systems will vary):
 - Baud rate: 115200 bps
 - Data bits: 8
 - Parity: None
 - Stop bits: 1
 - Flow control: None
4. Login to the device.
After the connection is established, a prompt for the username and password displays. Enter the username and password to access the CLI. The username and password should be provided by the Network Operating System (NOS) vendor.



12 Cable Connections

12.1 Connecting the USB Cable

Connect the USB 3.0 A Type plug (male connector) into the USB port (female connector) located on the front panel of the switch.



Figure 30.

12.2 Connecting the OOB Management Cables

Connect the OOB management cable by locating the RJ45 OOB port marked a  symbol.



Figure 31.

12.3 Connecting the Transceivers



Note

To prevent over tightening and damaging the optic fibers, it is not recommended to use tie wraps with optical cables.

Read the following guidelines before connecting the transceiver:

- Before installing the switch, take into consideration rack space requirements for cable management and plan accordingly.
- It is recommended to use hook-and-loop style straps to secure and organize the cables.
- For easier management, label each fiber-optic cable and record its respective connection.
- Maintain a clear line of sight to the port LEDs by routing the cables away from the LEDs.



Caution

Before connecting anything (cables, transceivers, etc.) to the switch, please ensure to discharge any static electricity that may have built up during handling. It is also recommended the cabling be done by a professional who is grounded, such as by wearing an ESD wrist strap.

Please follow the steps below for connecting a transceiver.

1. Remove the new transceiver from its protective packaging.
2. Remove the protective plug from the transceiver port.
3. Place the bail (wire handle) in the unlocked position and align the transceiver with the port.
4. Slide the transceiver into the port and use gentle pressure to secure it in place. An audible click can be heard when the transceiver is secured in the port.



13 Cautions and Regulatory Compliance Statements



Safety Notices

Caution! Shock hazard!

TO DISCONNECT POWER, REMOVE ALL POWER CORDS FROM UNIT.



Electrical Hazard: Only qualified personnel should perform installation procedures.
Risques d'électrocution: Seul un personnel qualifié doit effectuer les procédures d'installation.



Warning: Network Switch power supplies do not have switches for turning the unit on and off. Before servicing, disconnect all power cords to remove power from the device. Make sure that these connections are easily accessible.

Avertissement: Network Switch alimentations ne sont pas des interrupteurs pour allumer l'appareil et en dehors. Avant l'entretien, débranchez tous les cordons d'alimentation pour couper l'alimentation de l'appareil. Assurez-vous que ces connexions sont facilement accessibles.



Caution: Before mounting the device, ensure that the rack can support it without compromising stability. Otherwise, personal injury and/or equipment damage may result.



Caution: Use of controls or adjustments or performance of procedures other than those specified herein may result in hazardous radiation exposure.



Caution: Only Laser Class 1 optical transceivers shall be used.



Warning: Do not use optical instruments to view the laser output. The use of optical instruments to view laser output increases eye hazard. Use only UL/CSA, IEC/EN60825-1/-2 recognized pluggable modules.

Avertissement: Ne pas utiliser d'instruments optiques pour voir la sortie du laser. L'utilisation de instruments optiques pour afficher la sortie laser augmente les risques oculaires. Utilisez uniquement UL/CSA, IEC/EN60825-1 /-2 reconnu modules enfichables.



Warning:

The equipment should only be used within a restricted access area.

The equipment should only be operated by skilled or instructed persons.

The equipment and its modules should only be repaired, maintained or replaced by skilled personnel.

Instructed person is a term applied to persons who have been instructed and trained by a skilled person, or who is supervised by a skilled person.



<電源コードセットに関する使用上の注意事項>

付属の「AC電源コードセット」は、本製品専用のもので、他の電気機器には絶対に使用しないでください。

The logo for ufiSpace, featuring the word 'ufiSpace' in a bold, white, sans-serif font. The 'i' in 'ufi' has a dot, and the 'S' in 'Space' is capitalized. The logo is centered on a dark red, trapezoidal background that is part of a larger graphic design with geometric shapes and a gradient.

Unifying Cloud & Carrier Networks

www.ufispace.com