



## S9311-64D

400G Data Center

Spine Switch

**Hardware Installation Guide**

R1.2





# Table of Contents

<b>1</b>	<b>Overview</b> .....	<b>1</b>
<b>2</b>	<b>Preparation</b> .....	<b>2</b>
2.1	Installation Tools .....	2
2.2	Installation Environment Requirements .....	3
2.3	Preparation Check List.....	4
<b>3</b>	<b>Package Contents</b> .....	<b>5</b>
3.1	Accessory List .....	5
3.2	Component Physical Information.....	6
<b>4</b>	<b>Identifying Your System</b> .....	<b>7</b>
4.1	S9311-64D System Overview .....	7
4.2	DC Version PSU Overview .....	7
4.3	AC Version PSU Overview.....	8
4.4	Fan Overview .....	9
4.5	Port Overview.....	9
<b>5</b>	<b>Rack Mounting</b> .....	<b>11</b>
<b>6</b>	<b>Installing Fan Modules</b> .....	<b>14</b>
<b>7</b>	<b>Installing Power Supply Units</b> .....	<b>15</b>
<b>8</b>	<b>Grounding the Switch</b> .....	<b>17</b>
<b>9</b>	<b>Connecting Power</b> .....	<b>19</b>
9.1	DC Version .....	19
9.2	AC version.....	20
<b>10</b>	<b>Verifying System Operation</b> .....	<b>21</b>
10.1	Front Panel LED .....	21
10.2	PSU FRU LED .....	22
10.3	Fan FRU LED.....	22
10.4	Management Port LED .....	22
<b>11</b>	<b>Initial System Setup</b> .....	<b>23</b>
<b>12</b>	<b>Cable Connections</b> .....	<b>25</b>
12.1	Connecting the USB Cable.....	25
12.2	Connecting the OOB Management Cables.....	25

12.3	Connecting the 1PPS Interface.....	25
12.4	Connecting the 10MHz Interface .....	26
12.5	Connecting the Transceivers .....	26
<b>13</b>	<b>Cautions and Regulatory Compliance Statements .....</b>	<b>28</b>



# 1 Overview

The UfiSpace S9311-64D is a next-generation, ultra-high-density data center networking white box switch that is designed to address the exponential bandwidth demands of hyperscale data centers and AI/ML fabrics and the need to push network capacity and scale to the next level.

With 64 x 400GE QSFP-DD ports, the S9311-64D data center switch acts as a high-capacity aggregation point, ideal for interconnecting large clusters of high-performance compute and storage resources with non-blocking, line-rate Ethernet connectivity.

This switch delivers an incredible 25.6 Tbps of throughput in a power-efficient 2RU form factor, helping operators to increase rack density while managing operational expenses like power and cooling.

The S9311-64D provides the foundation for next-generation networks with its powerful Tomahawk 4 processor and 64 high-speed 400GE interfaces. It is built for mission-critical reliability, featuring 1+1 hot-swappable power supplies and 3+1 redundant fans for maximum uptime, simplified serviceability, and enhanced operational stability.

This document describes the hardware installation process for S9311-64D.



## 2 Preparation

### 2.1 Installation Tools



Screwdriver (Phillips head #2)

Phillips #2 Screw Driver

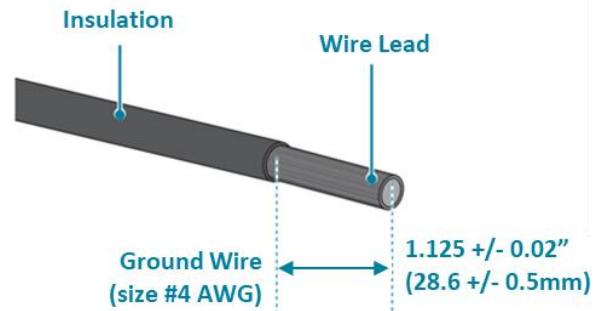

4-AWG green-and-yellow wire for grounding

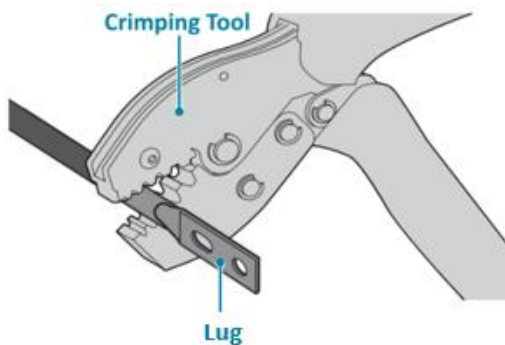

Crimping tool



Wire stripping tool



#### Note

All illustrations within this document are for reference purposes only. Actual objects may differ.

- PC with terminal emulation software. Refer to the "Initial System Setup" section for details.
  - Baud rate: 115200 bps
  - Data bits: 8
  - Parity: None
  - Stop bits: 1
  - Flow control: None

## 2.2 Installation Environment Requirements

- Power Reserve: The S9311-64D power supply is available with:
  1. **DC Version:** 1+1 active-active -48 to -60V DC power supply field replaceable unit or;
  2. **AC Version:** 1+1 active-active 200 to 240V AC power supply field replaceable unit.

To ensure the active-active feed power design functions properly, a field with dual power circuit is recommend with a reserve of at least 2400 watts on each power circuit.

- Space Clearance: The S9311-64D width is 17.16 inches (43.6cm) and shipped with a rack mount brackets suitable for 19 inch (48.3cm) wide racks. The depth of the S9311-64D chassis is 22.8 inches (58.0cm) without the field replaceable units (FRUs) and comes with adjustable check mounting rails suitable for rack depths of 20 inches (50.8cm) to 35 inches (88.9cm). The handle for the fan units will extend outwards by 1.15 inch (2.9cm) and the handle for the power supplies will extend outwards by 1.19 inches (3cm). Therefore, to accommodate the fan and power supply handles, a minimum space clearance of 6 inches (15.2cm) is needed at the back and front of the S9311-64D. A total minimum reserve depth of 34.8 inches (88.39cm) is required.

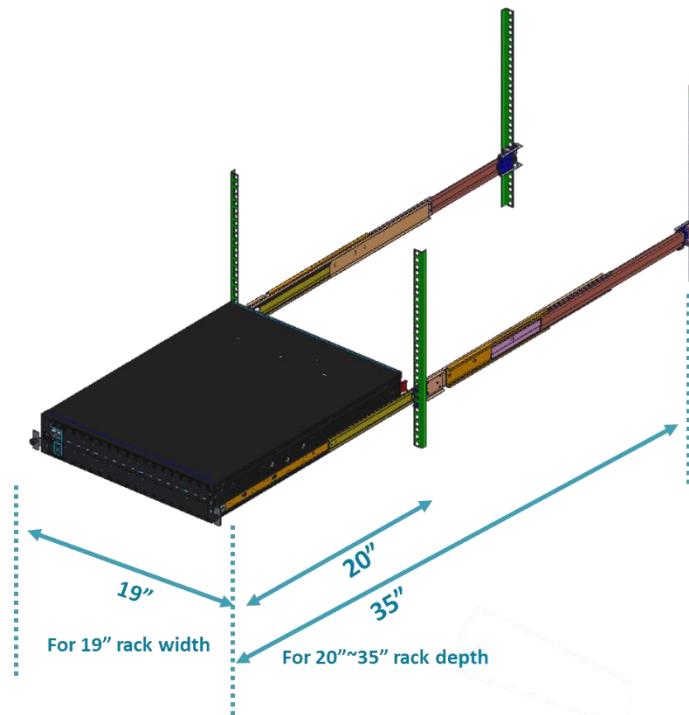

Figure 1

- Cooling: The S9311-64D has two options for airflow direction. There is a front-to-back option (Figure 3. Left) and a back-to-front option (Figure 3. Right). Make sure the equipment on the same rack have the same airflow direction.



### Note

Ensure all installed fans and power supply units (PSUs) have matching airflow directions (indicated by the same handle color) to maintain proper system operation.

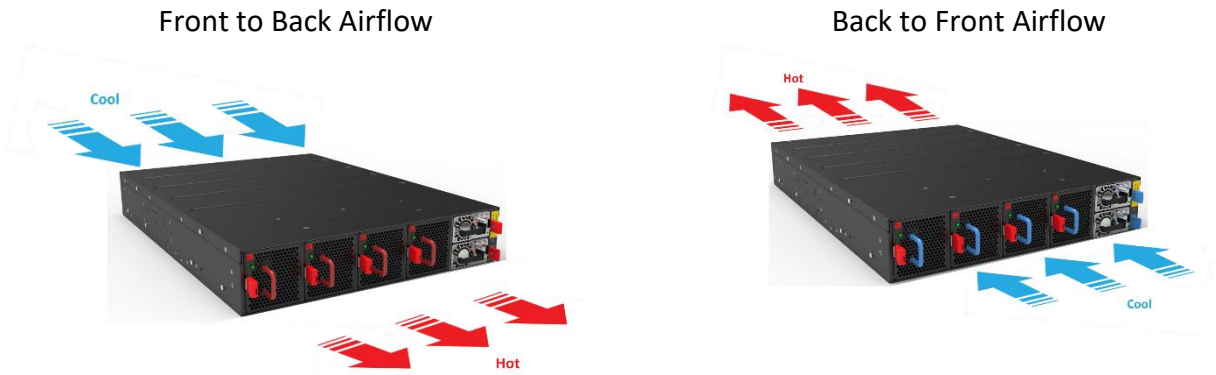

Figure 2

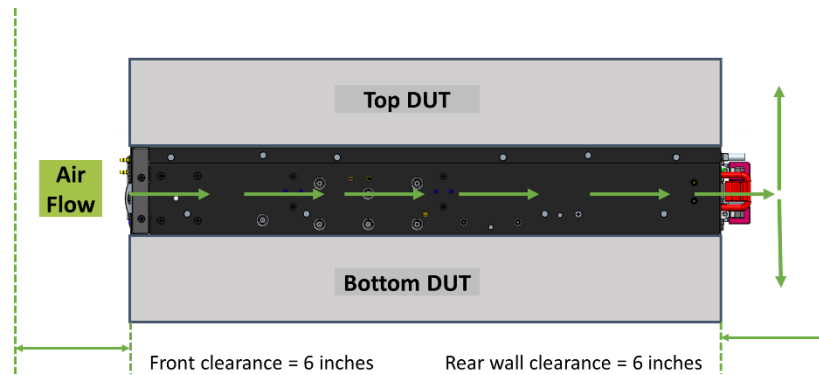

Figure 3

## 2.3 Preparation Check List

Task	Check	Date
<b>Power voltage and electric current requirement</b> <b>DC version:</b> -48 to -60V DC, 70Ax2 maximum or; <b>AC version:</b> 200 to 240V, 15A x2 maximum		
<b>Installation spacing requirement:</b> S9311-64D requires 2RU (3.45"/8.8cm) in height, 19" (48.3cm) in width, and need a minimum reserve depth of 34.8 inches (88.39cm)		
<b>Thermal requirement</b> S9311-64D working temperature is 0 to 40°C (32°F to 104°F), airflow direction is front-to-back or back-to-front		
<b>Installation tools required</b> #2 Philips Screwdriver, 4-AWG yellow-and-green wire stripper, and crimping tool		
<b>Accessories required</b> PC with terminal emulation software		



## 3 Package Contents

### 3.1 Accessory List

Item	Description	Spec. & Dimensions	Qty.	Weight
1	Grounding Lug and Screw Kit	1x Grounding Lugs (#4 AWG) 1.65" x 1.45" x 0.55" (41.91 x 36.83 x 13.97mm) 2x Screws M4*L8.0mm 2x M4 Lock Washers	1 set	0.05lb (21.1g)/1 set
2	DC Power Cable (DC version Only)	137.8"(3500mm)	2 pcs	6.6lb (3.0kg)/2pcs 3.3lb (1.5kg)/1pcs
3	AC Power Cord (AC version Only)	72.05" (1830mm)	2 pcs	1.54lb (700g)/ 2 pcs 0.77lb (350g)/1 pcs
4	RJ45 to DB9 Female Cable	8' (2438mm)	1 pcs	0.23lb (105g)/1 pcs
5	USB 3.0 Cable	7.87" (200mm)	1 pcs	0.03lb (13.6g)/ 1 pcs
6	Micro USB Cable	3.28' (1000mm)	1 pcs	0.05lb (24.4g)/1 pcs
7	Adjustable Mounting Rail (for 4 post)	23.56"x 1.7" x 0.9" (598.3 x 44 x 22mm) (20"~35" rack depth)	2 sets	7.05lb (3.2kg)/2 sets 3.53lb (1.6kg)/1 set
8	Screw Kit (for Rack Mount Bracket)	2 x Screw M4.0*L5.5	1 set	0.004lb (1.9g)/1 set

## 3.2 Component Physical Information

Specification	Item	Description
Weight	Total package contents	83.54lb (37.9kg)
	Chassis without FRU	40.83lb (18.52kg)
	Power Supply Unit (PSU)	DC PSU: 2.05lb (0.93kg)
		AC PSU: 2.27lb (1.03kg)
	Fan module unit	1.41lb (638g)
	Ground lug	0.05lb (21.1g)
	Adjustable mounting rail	3.53lb (1.6kg)
	Micro USB cable	0.05lb (24.4g)
	RJ45 to DB9 female cable	0.23lb (105g)
	DC power cable (DC version only)	3.3lb (1.5 kg)
	AC power cord (AC version only)	0.77lb (350g)/1 pcs
	USB 3.0 cable	0.03lb (13.6g)
Dimension	S9311-64D (W x D x H)	17.16" x 22.83" x 3.45" (436 x 580 x 87.7mm)
	PSU (W x D x H)	2.89" x 7.28" x 1.57" (73.5 x 185 x 40mm)
	Fan (W x D x H)	3.19" x 6.95" x 3.21" (81 x 176.53 x 81.5mm)



## 4 Identifying Your System

### 4.1 S9311-64D System Overview

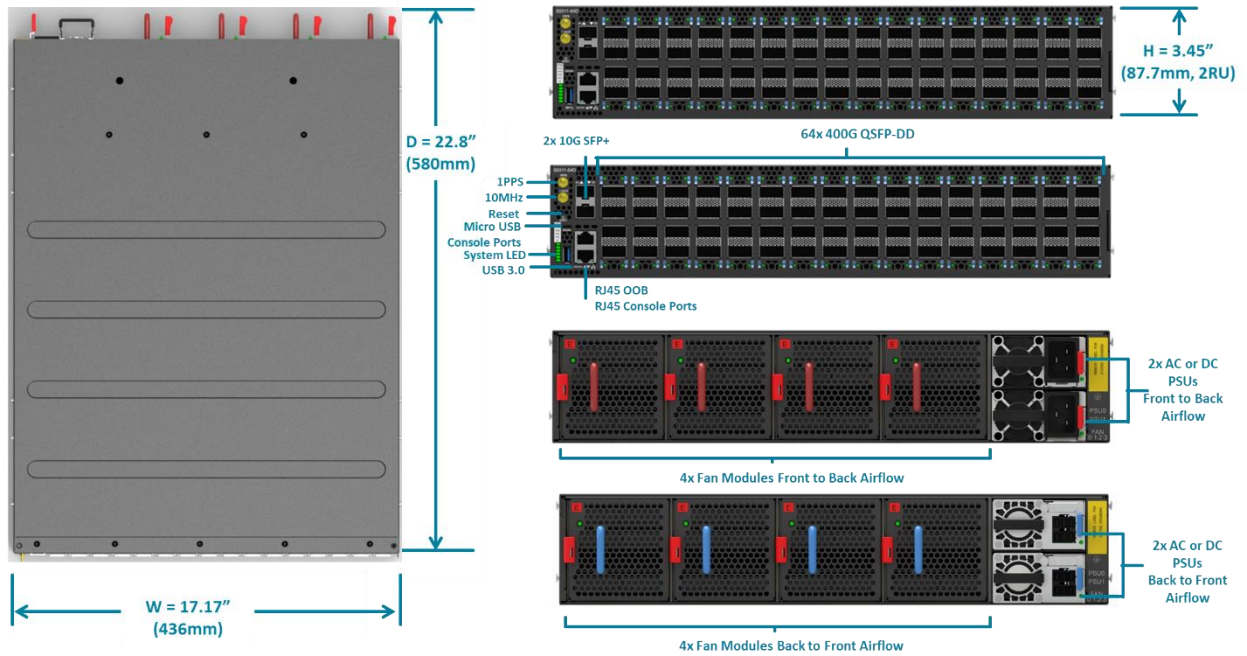

Figure 4

### 4.2 DC Version PSU Overview

1+1, hot swappable power supply unit (PSU) field replaceable unit (FRU). There are two types of DC PSUs. The picture is the DC PSU with front-to-back airflow, identified with a red latch. The outlook of DC PSU for back-to-front airflow is the same and can be identified with a blue latch.

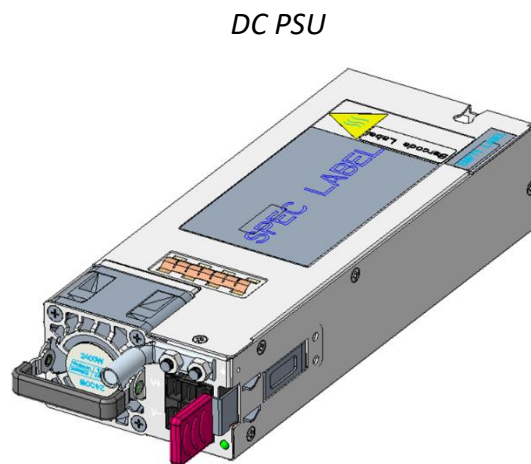
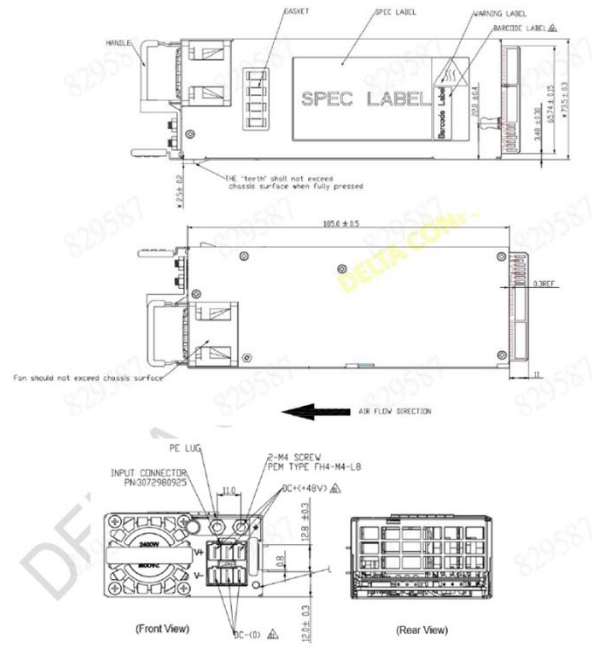

Figure 5

The DC power supply units are the same size for both back-to-front airflow and front-to-back airflow. Therefore, only the dimensions for front-to-back airflow PSU will be provided in the figure below.



(Front-to-Back Airflow PSU)

Figure 6

### 4.3 AC Version PSU Overview

1+1, hot swappable power supply unit (PSU) field replaceable unit (FRU). There are two types of AC PSUs. The picture is the AC PSU with front-to-back airflow, identified with a red latch. The outlook of AC PSU for back-to-front airflow is the same and can be identified with a blue latch.

AC PSU

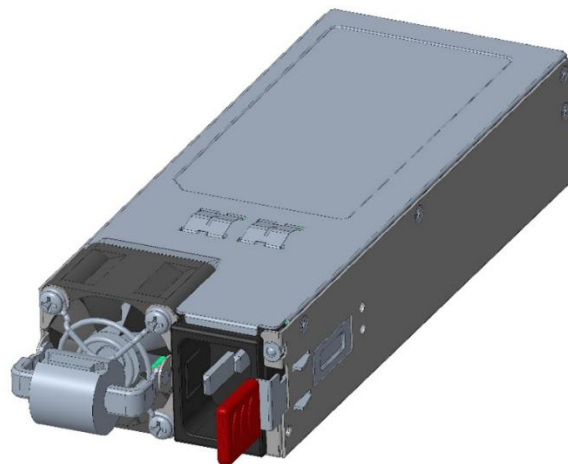

Figure 7

The AC power supply units are the same size for both back-to-front airflow and front-to-back airflow. Therefore, only the dimensions for front-to-back airflow PSU will be provided in the figure below.

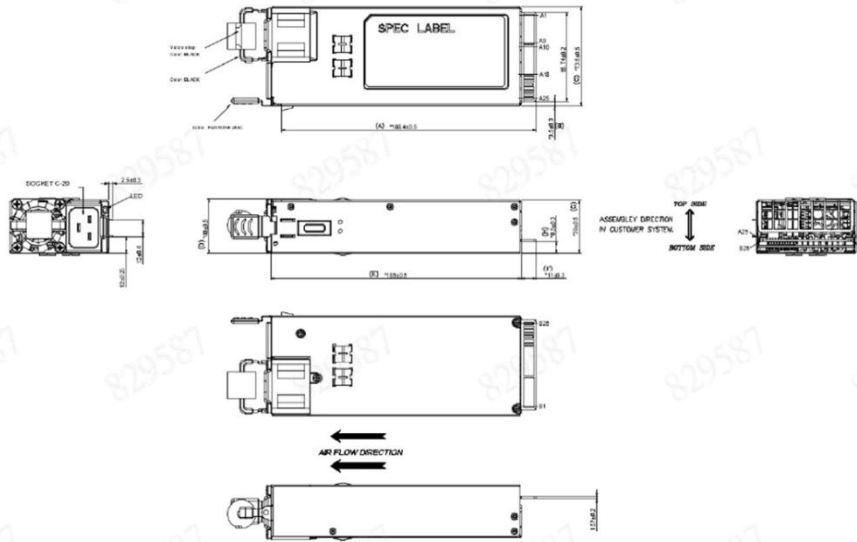

Figure 11 : Mechanical Outline Drawing

(Front-to-Back Airflow PSU)

Figure 8

## 4.4 Fan Overview

3+1, hot swappable fan field replaceable unit (FRU). There are two types of fans. The picture shown in Figure 10 is for fans with front-to-back airflow, identified with a red handle. The outlook of fan for back-to-front airflow is the same and can be identified with a blue latch.

	<p><b>Note</b></p>	<p>Ensure all installed fans and power supply units (PSUs) have matching airflow directions (indicated by the same handle color) to maintain proper system operation.</p>
--	--------------------	---

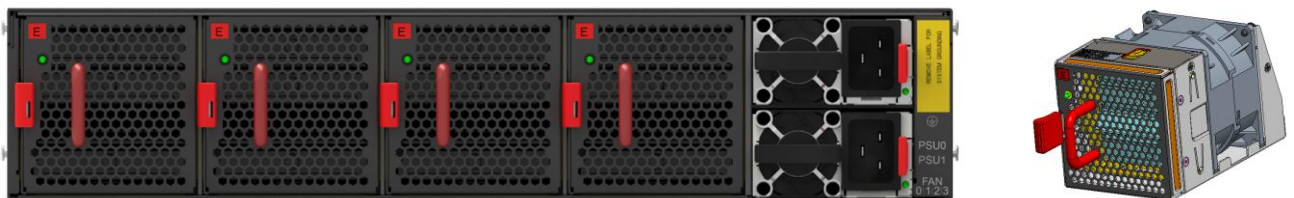

Figure 9

## 4.5 Port Overview

Port ID	Form Factor	Maximum Support Distance	Support Speed
0 ~ 63	QSFP-DD	49.7mi (80km)	40/100/200/400G

---

64~65

SFP+

6.21mi (10km)

1/10G

---

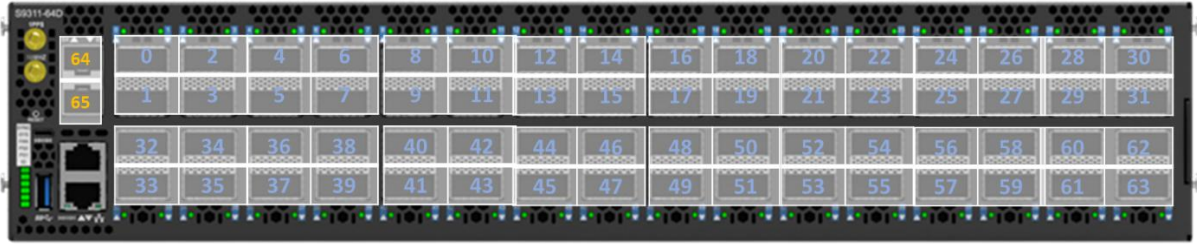

Figure 101

The 400G QSFP-DD ports highlighted support both ZR+ transceivers up to 32 units.

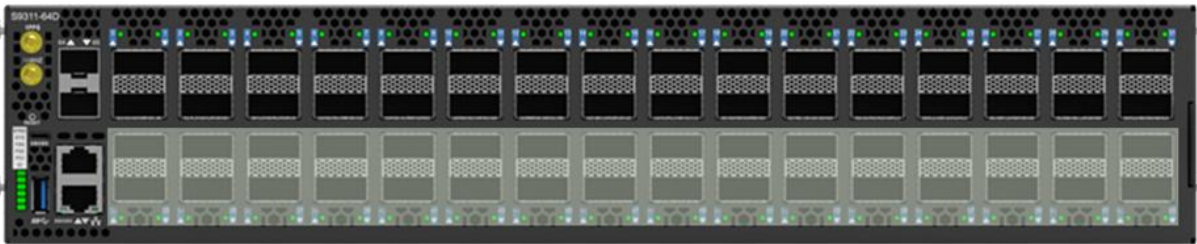

Figure 12



## 5 Rack Mounting



**Caution**

It is recommended that installation be done by two trained professionals. One individual should hold the equipment in position on the rack while the other secures it in place.

1. Separate the adjustable rail slides.
  - 1.1 Pull apart the inner and outer rails until it is locked in place. An audible click can be heard when the rails are locked in place.
  - 1.2 Pull the white tab forward to unlock the rails in order to completely separate the inner rail from the outer rail. The white tab is located on the inner rail.
  - 1.3 Once the inner rail is separated, push the tab located on the outer rail to unlock and slide the middle rail back.

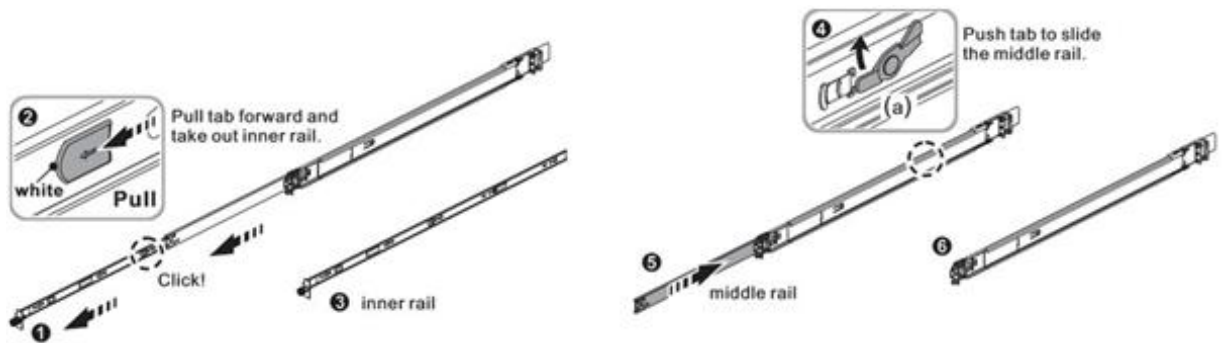

Figure 11

2. Install the inner rails onto the chassis.
  - 2.1 The inner rail has key-shaped holes where attachment pins on the chassis can be aligned. The chassis has 4 attachment pins on each side, for a total of 8 pins. Fit the key-shaped holes with the attachment pins and pull back to hold the inner rack in place.



**Note**

Make sure the captive screw of the inner rail is positioned at the front of the chassis.

- 2.2 After the attachment pins are secured to the inner rail, lock the inner rail to the chassis using two M4 screws (one on each chassis side). See the figure below.

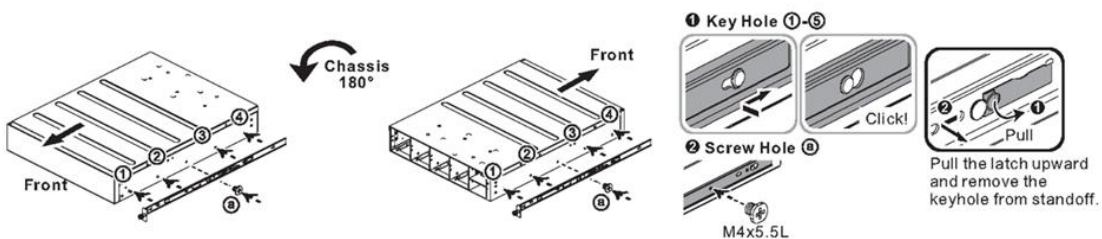

Figure 12

- 3 Fix the outer rails onto the rack.
  - 3.1 The outer rails have two brackets on the front and rear. Pull back the clip of the rear bracket to attach it onto the rack. An audible click can be heard when the bracket is secured onto the rack.
  - 3.2 Once the rear bracket is secured, pull back the clip of the front bracket attach it to the rack. An audible click can be heard when the bracket is secured onto the rack.

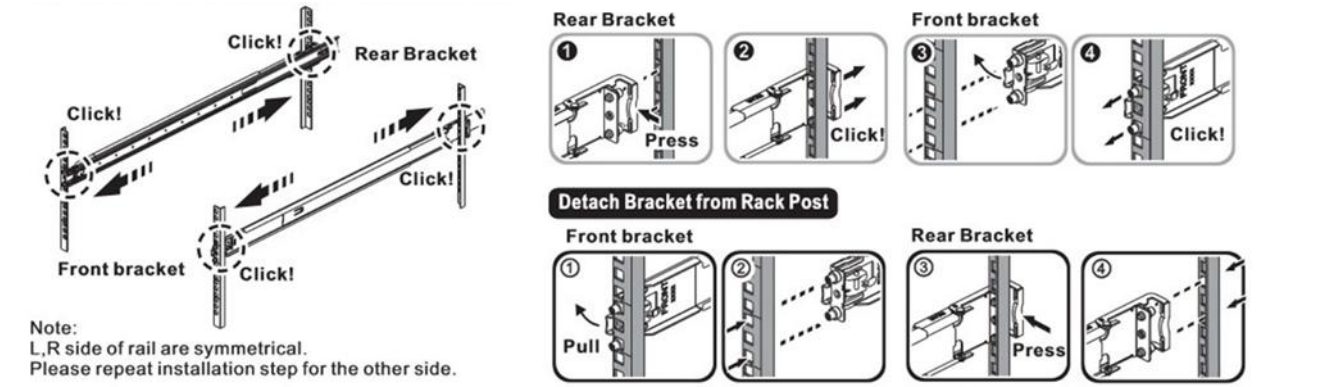
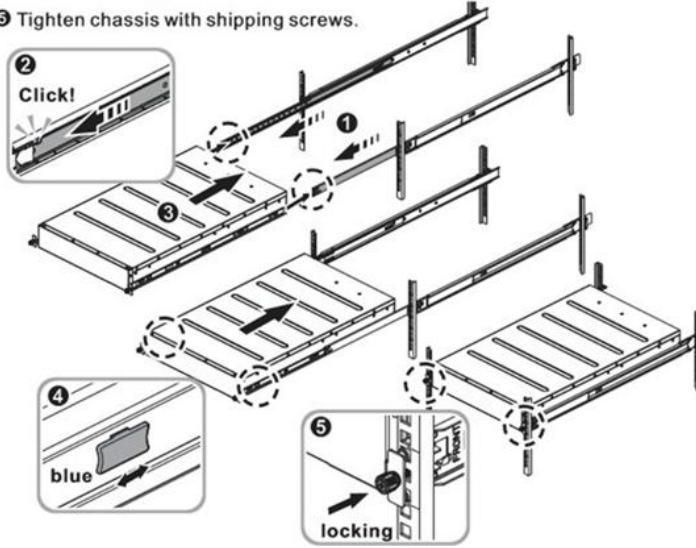

Figure 13

- 4 Insert the Chassis to complete the installation.
  - 4.1 Pull the middle rail fully extended into lock position, an audible click can be heard when the middle rail is fully extended and locked into position.
  - 4.2 Insert the chassis by lining up the inner rails into the slot of the middle rail.
  - 4.3 Slide the chassis into the middle rail until it hits a stop.
  - 4.4 Push the blue release tab on each rail to unlock the rails and slide the chassis all the way into the rack.
  - 4.5 Lock the chassis into place by using the screw on the front of the inner rail with a torque value of 22.5 +/- 2.0kgf.cm.

- 1 2 Pull the middle rail fully extended in lock position, ensure ball bearing retainer is located at the front of the middle rail.
- 3 Insert the chassis into middle-outer rails.
- 4 When hit a stop, please push the release tab on middle rail.
- 5 Tighten chassis with shipping screws.



#### Remove the chassis from rack

- 1 2 Loosen shipping screw to pull out chassis.
- 3 4 Press the disconnect tab forward to remove chassis.
- 5 6 Push tab to slide the middle rail.

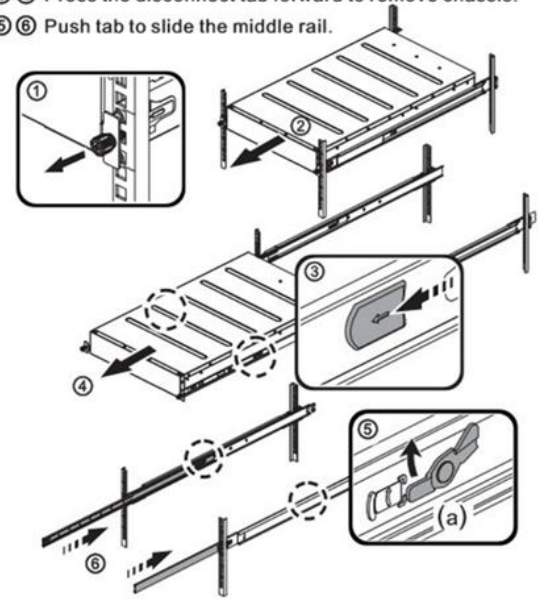

Figure 14



## 6 Installing Fan Modules

The fan modules are hot swappable field replaceable units (FRUs), which can be replaced while the switch is operating as long as all the remaining modules are installed and in operation. The fans come pre-installed and the following steps are instructions on how to install a new fan module.

1. Locate the release tab on the fan module. Then press and hold the release tab to unlock the fan module.

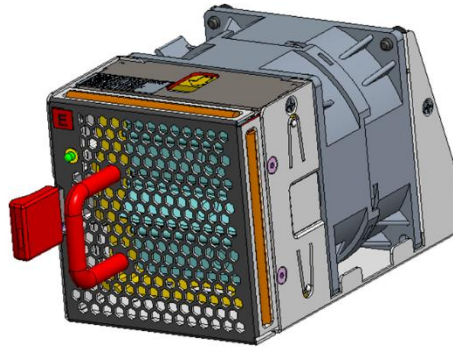

Figure 15

2. While holding down the release tab, grip the fan handle and gently pull the fan module out of the fan bay.

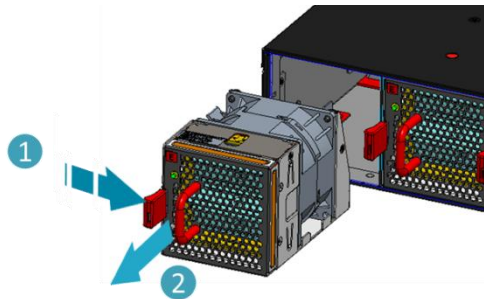

Figure 16

3. Align the new fan module with the fan bay, ensuring that the fan module's power connector is in the correct position.
4. Carefully slide the new fan module into the fan bay and gently push until it is flush with the case.
5. An audible click will be heard when the fan module is installed correctly. The fan module will not go in all the way if it is installed in the wrong direction.

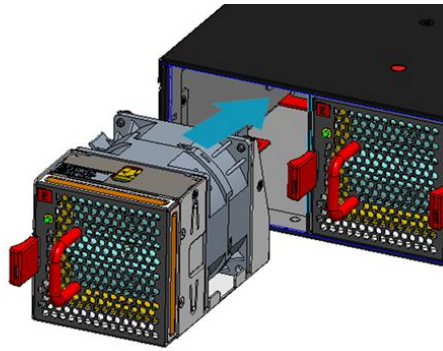

Figure 17

## 7 Installing Power Supply Units

The power supply unit (PSU) is a hot swappable field replaceable unit (FRU) and can be replaced while the switch is operating as long as the remaining (second) PSU is installed and in operation. The PSUs comes pre-installed and the following are instructions on how to install a new PSU. The process for removing and installing the PSUs are the same for all models.



If power input for AC power supply is only 110V, there will only be 1000 watts per power supply and will not be enough power for the power supply to be changed while the switch is in operation. In order for AC power supply to be changed while the switch is in operation, ensure that 220V power is supplied.

DC:

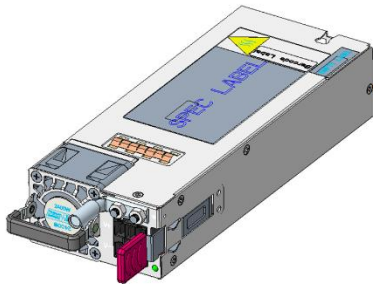

AC:

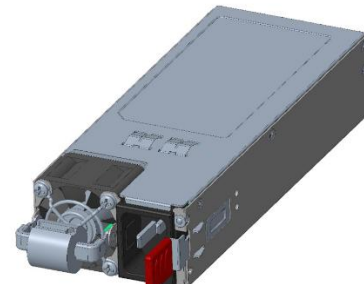

Figure 18



**Shock hazard!**  
For safety, please disconnect all power inputs from the power supply unit before servicing the switch.

1. Locate the release tab on the PSU. Then press and hold down the release tab to unlock the PSU from the power bay.
2. While holding down the release tab, grip the PSU's handle and firmly pull it out of the power bay.

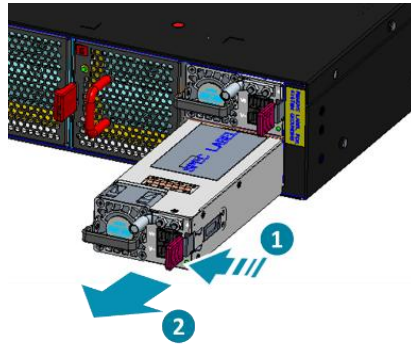

Figure 19

3. Align the new PSU with the power bay, ensuring the PSU's power connector is in the correct position.
4. Carefully slide the new PSU into the power bay and gently push until it is flush with the case.
5. An audible click will be heard when the PSU is installed correctly. The PSU will not go in all the way if it is in the wrong direction.



**Note**

Illustrations are for reference purposes only. Actual PSU position may differ.

DC Version:

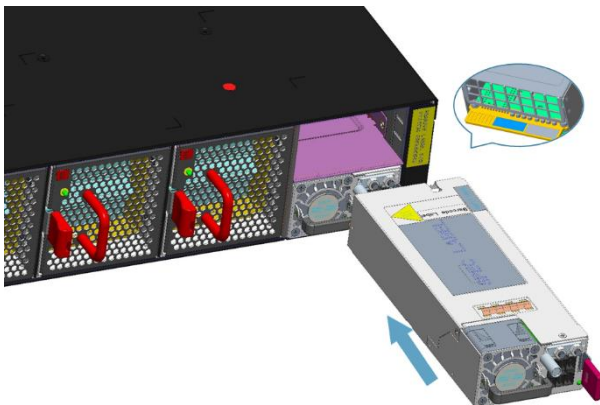

AC Version:

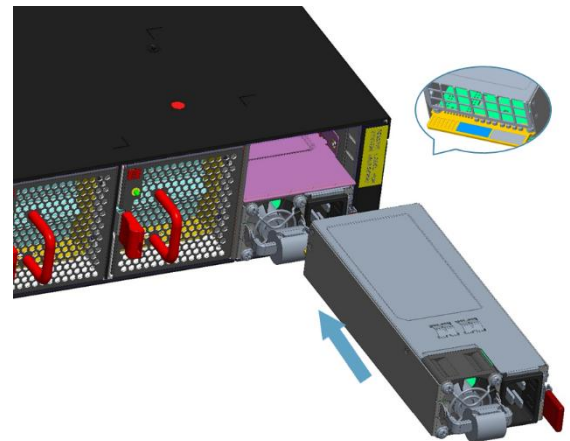

Figure 20



## 8 Grounding the Switch

It is recommended that equipment changes be done on a grounded rack system. This will reduce or prevent the risk of shock hazards, equipment damage, and potential of data corruption.

The switch can be grounded from the switch's case, a grounding lug and M4 screws and washers are provided with the package contents, however, the grounding wire is not included. For convenience, there are two locations on the case in which the grounding lug may be fixed.

The following instructions are for grounding the switch.



This equipment must be grounded. Do not defeat the ground conductor or operate the equipment without correctly grounding the equipment. If there is any uncertainty about the integrity of the equipment's grounding, please contact the electrical inspection authority or a certified electrician.

1. Before grounding the switch, ensure that the rack is properly grounded and in compliance with local regulatory guidelines. Ensure that there is nothing that can obstruct the connection for grounding and remove any paint or materials that may prevent good grounding contact.
2. Strip the insulation from a size #4 AWG grounding wire (not provided within the package contents), leaving 0.5" +/- 0.02" (12.7mm +/- 0.5mm) of exposed grounding wire.
3. Insert the exposed grounding wire all the way into the hole of the grounding lug (provided with package contents).
4. Using a crimping tool, firmly secure the grounding wire to the grounding lug.

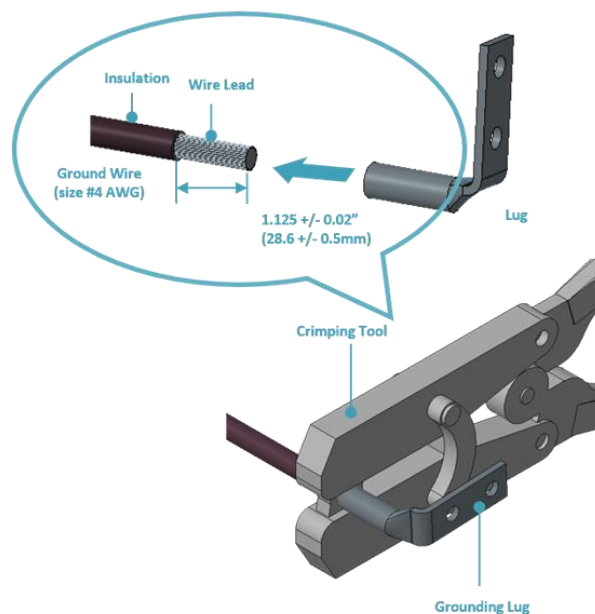

Figure 21

5. Locate the designated location for securing the grounding lug, which is located on the side of

the switch and remove the protective label.

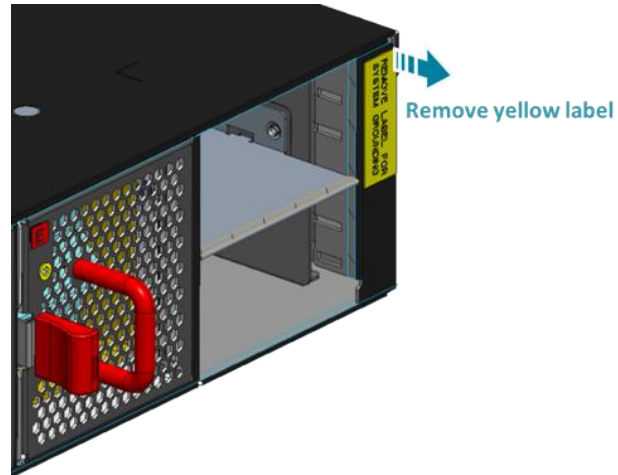

Figure 22

- Using 2 M4 screws and 2 washers (provided with the package contents), firmly lock the grounding lug to either of the designated grounding locations on the switch.

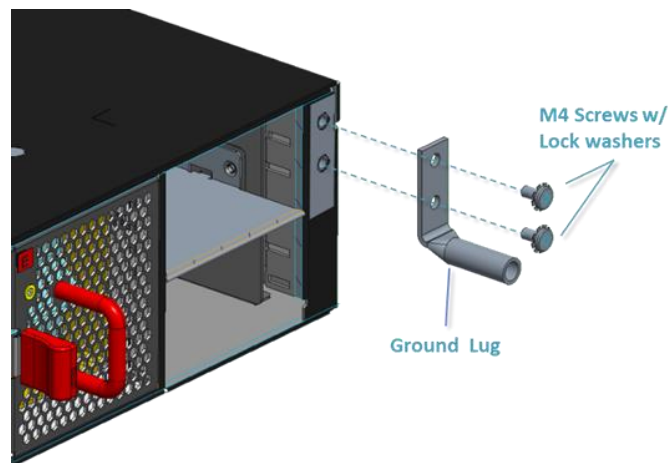

Figure 23



## 9 Connecting Power



### Note

All power cables must be routed entirely within the designated rack cable management areas and fixed properly using appropriate strain relief and fasteners.

### 9.1 DC Version

1. Ensure there is enough power to supply the system.  
The maximum system power consumption is 2097 watts. It is recommended to ensure that enough power is reserved from the power distribution system before installation. Also, please ensure that both PSUs have been properly installed before powering up the equipment, as the S9311-64D is designed to support 1 + 1 power redundancy.
2. Locate the inlet connector on the DC power supply (PSU), then securely connect the DC power cable to it.
3. A 'click' sound indicates that the connection has been securely completed.



Figure 24



### Note

Illustrations are for reference purposes only. Actual PSU and cable may differ.

4. Feed DC power into the system.  
Use a -48V to -60V DC power source rated for operation up to 5000 meters, and be aware that the system will receive 12V and 12VSB power instantly upon connection. The PSU has a built in 120A, fast acting fuse based on the PSU maximum capacity, which will act as a second tier system protection in case the power distribution unit's fuse is not functioning.
5. Verify that the power supply is operating.  
If connected correctly, when turned on, the LED on the PSU will light up with a Green color designating normal operation.
6. Disconnect the power cable.  
Locate the pull handle on the DC power cable and gently pull it outward to disconnect the cable.

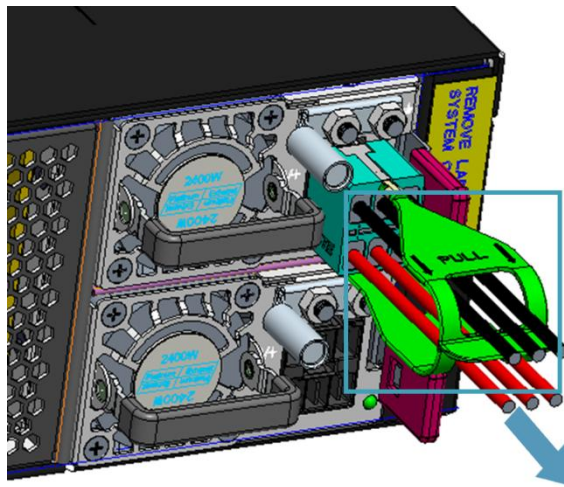

Figure 25

## 9.2 AC version

1. Ensure there is enough power to supply the system.  
The maximum system power consumption is 2096 watts. It is recommended to ensure that enough power is reserved from the power distribution system before installation. Also, please ensure that both PSUs have been properly installed before powering up the equipment, as the S9311-64D is designed to support 1 + 1 power redundancy.
2. Attach the power cable.  
Locate the AC inlet connector on the PSU and plug the AC power cable (250VAC 15A, IEC60320 C19) into the AC inlet connector.
3. Feed AC power into the system.  
Use a 200V to 240V AC power source rated for operation up to 5000 meters, and be aware that the system will receive 12V and 12VSB power instantly upon connection. The PSU has a built-in 15A, fast acting fuse based on the PSU maximum capacity, which will act as a second-tier system protection in case the power distribution unit's fuse is not functioning.
4. Verify that the power supply is operating.  
If connected correctly, when turned on, the LED on the PSU will light up with a solid Green color designating normal operation.



### Note

If only a 110V AC power source is available, the S9311-64D can still be powered with both PSUs providing 1200 watts each for a total output of 2400 watts. However, in this case, if one PSU stops functioning, the power output would be inefficient to sustain the switch's operation.



# 10 Verifying System Operation

## 10.1 Front Panel LED

Verify basic operations by checking the system LEDs located on the front panel. When operating normally, the SYS, FAN, and PSU LEDs should all display green.

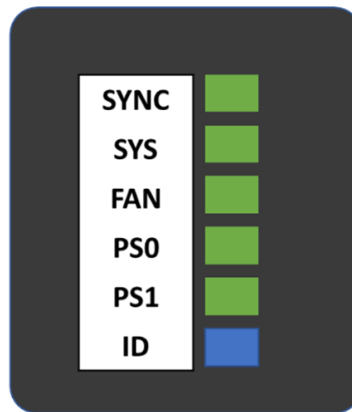

Figure 26

LED Condition	Equipment Status
<b>SYNC</b>	
Off	System timing/clock synchronization is disable or in free-run mode
Solid Green	System timing core is synchronized to PTP packet (Phase) or one of the external timing sources (Phase) and frequency is locked.
Blinking Green	System timing is synchronized to PTP packet (Frequency) or one of the external timing (Frequency) sources
Solid Amber	System timing core is in acquiring state or holdover mode
Blinking Amber	System timing synchronization fail or acquiring/holdover time out
<b>SYS</b>	
Off	No power
Solid Green	Host CPU/BMC boot complete
Solid Amber	Power is up but Host CPU/BMC boot failed
<b>FAN</b>	
Off	Fans are not initialized
Solid Green	All Fans are work normal
Blinking Amber	Fan fail: one or more Fans need service
<b>PS0</b>	
Off	No power
Solid Green	PSU0 working normal
Blinking Amber	PSU0 fail (PSU0 needs service)
<b>PS1</b>	
Off	No power

Solid Green	PSU1 working normal
Blinking Amber	PSU1 fail (PSU1 needs service)
<b>ID</b>	
Off	No Power
Blinking Blue	Beacon feature is enabled on the switch

## 10.2 PSU FRU LED

Additional information about PSU status can be obtained by the LEDs located on the PSU itself.

LED Condition	Equipment Status
Off	No input power to all power supplies
Solid Green	Output ON and OK.
Blinking Green (1Hz)	PSU input power present / Only +12VSB on.
Blinking Green (2Hz)	Power supply firmware updating (Boot-loader mode).
Solid Amber	Input out of range with a second power supply in parallel still with AC input power.
	Power supply critical event causing a shutdown, OTP, OVP, UVP, OCP
Blinking Amber (1Hz)	Power supply warning events where the power supply continues to operate; high temp, high power, high current, and/or slow fan.

OTP: Over Temperature Protection, OVP: Over Voltage Protection, UVP: Under Voltage Protection, OCP: Over Current Protection

## 10.3 Fan FRU LED

LED Condition	Equipment Status
Off	No input power
Solid Green	Fan is functioning normal
Solid Yellow	Fan is abnormal, service is required

## 10.4 Management Port LED

LED Condition	Equipment Status
<b>Left LED</b>	
Off	No power
Solid Green	1G link-up
Blinking Green	1G TX/RX activity
<b>Right LED</b>	
Off	No power
Solid Amber	10M/100M link-up
Blinking Amber	10M/100M TX/RX activity



# 11 Initial System Setup

Establishing a first-time serial connection.

To assign an IP address, you must have access to the command line interface (CLI). The CLI is a text-based interface that can be accessed through a direct serial connection to the device.

Access the CLI by connecting to the console port. After you assign an IP address, you can access the system through Telnet or SSH by Putty, TeraTerm or HyperTerminal.

Perform the following steps to access the device through a serial connection:

1. Connect the console cable.
  - The console can be connected either with the IOIO port or the micro USB port. If connecting with USB, drivers will need to be installed.
  - To connect the console using the IOIO port, locate the port labelled IOIO, then plug a serial cable into the console port and connect the other end to the PC or laptop. Cable types may vary depending on the switch model.

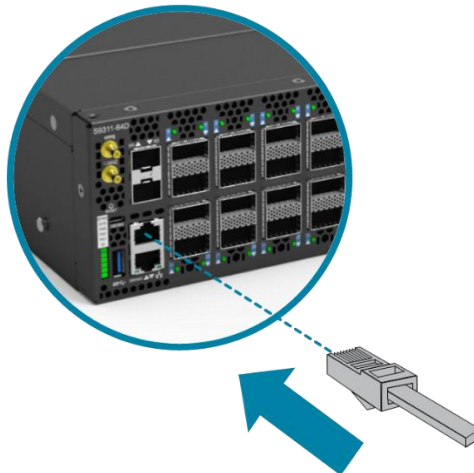

Figure 27

- To connect the console using the micro USB port, locate the port on the front panel of the switch, then connect your computer using the micro USB cable provided in the packaging contents. Download the suitable driver for your operating system (OS) using the URL below:
  - <https://www.silabs.com/products/development-tools/software/usb-to-uart-bridge-vcp-drivers>
  - <https://www.silabs.com/> and search for CP210X

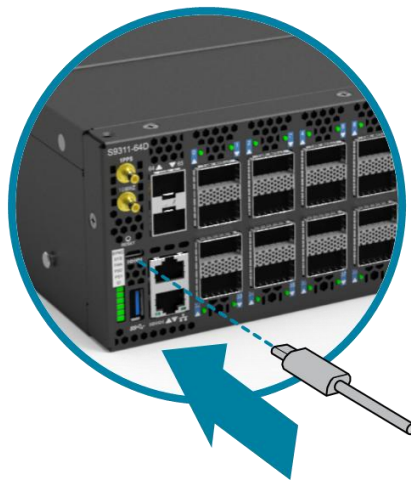

Figure 28

2. Check for serial control availability.  
Disable any serial communication programs running on the computer such as synchronization programs to prevent interference.
3. Launch a terminal emulator.  
Open a terminal emulator application such as HyperTerminal (Windows PC), Putty or TeraTerm and configure the application. The following settings are for a Windows environment (other operating systems will vary):
  - Baud rate: 115200 bps
  - Data bits: 8
  - Parity: None
  - Stop bits: 1
  - Flow control: None
4. Login to the device.  
After the connection is established, a prompt for the username and password displays. Enter the username and password to access the CLI. The username and password should be provided by the Network Operating System (NOS) vendor.



## 12 Cable Connections

### 12.1 Connecting the USB Cable

Connect the USB 3.0 A Type plug (male connector) into the USB port (female connector) located on the front panel of the switch.

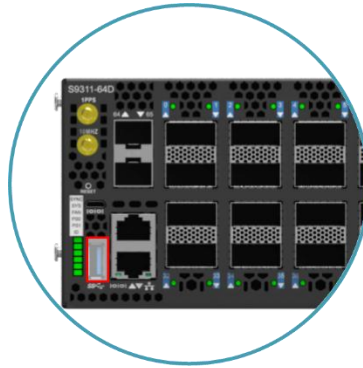



Figure 29

### 12.2 Connecting the OOB Management Cables



**Note**

We recommend that you use a Category 5 (Cat 5e) cable for the OOB management.

The OOB management port marked a  symbol can access the x86 for management purposes.

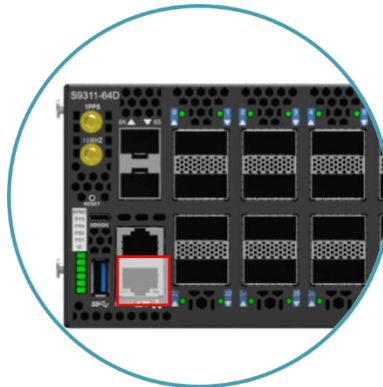

Figure 30

### 12.3 Connecting the 1PPS Interface



**Note**

The maximum length of the 1PPS coaxial SMB/1PPS Ethernet cable should not

be more than 3 meters.

Connect an external 1PPS cable with an impedance of 50 ohms to the port labelled "1PPS".

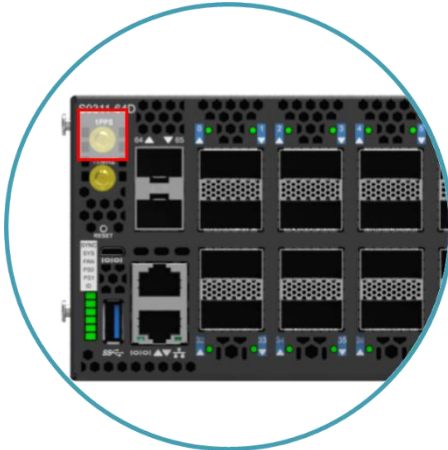

Figure 31

### 12.4 Connecting the 10MHz Interface

**Note** The maximum length of the 10MHz coaxial SMB cable should not be more than 3 meters.

Connect an external 10MHz cable with an impedance of 50 ohms to the port labelled "10MHz".

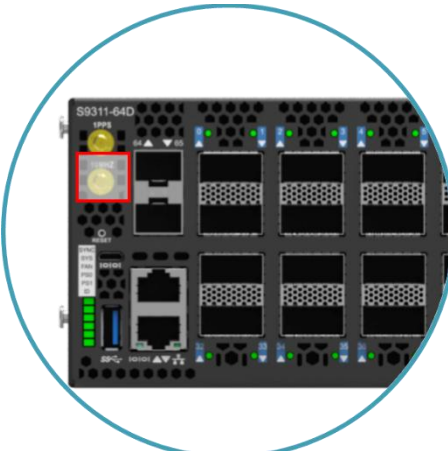

Figure 32

### 12.5 Connecting the Transceivers

**Note** To prevent over tightening and damaging the optic fibers, it is not recommended to use tie wraps with optical cables.

Read the following guidelines before connecting the transceiver:

- Before installing the switch, take into consideration rack space requirements for cable management and plan accordingly.
- It is recommended to use hook-and-loop style straps to secure and organize the cables.

- For easier management, label each fiber-optic cable and record its respective connection.
- Maintain a clear line of sight to the port LEDs by routing the cables away from the LEDs.



**Caution**

Before connecting anything (cables, transceivers, etc.) to the switch, please ensure to discharge any static electricity that may have built up during handling. It is also recommended the cabling be done by a professional who is grounded, such as by wearing an ESD wrist strap.

Please follow the steps below for connecting a transceiver.

1. Remove the new transceiver from its protective packaging.
2. Remove the protective plug from the transceiver port.
3. Place the bail (wire handle) in the unlocked position and align the transceiver with the port.
4. Slide the transceiver into the port and use gentle pressure to secure it in place. An audible click can be heard when the transceiver is secured in the port.



5.

## 13 Cautions and Regulatory Compliance Statements



### Safety Notices

#### Caution! Shock hazard!

TO DISCONNECT POWER, REMOVE ALL POWER CORDS FROM UNIT.



**Electrical Hazard:** Only qualified personnel should perform installation procedures.

**Risques d'électrocution:** Seul un personnel qualifié doit effectuer les procédures d'installation.



**Warning:** Network Switch power supplies do not have switches for turning the unit on and off. Before servicing, disconnect all power cords to remove power from the device. Make sure that these connections are easily accessible.

**Avertissement:** Network Switch alimentations ne sont pas des interrupteurs pour allumer l'appareil et en dehors. Avant l'entretien, débranchez tous les cordons d'alimentation pour couper l'alimentation de l'appareil. Assurez-vous que ces connexions sont facilement accessibles.



**Caution:** Before mounting the device, ensure that the rack can support it without compromising stability. Otherwise, personal injury and/or equipment damage may result.



**Caution:** Use of controls or adjustments or performance of procedures other than those specified herein may result in hazardous radiation exposure.



**Caution:** Only Laser Class 1 optical transceivers shall be used.



**Warning:** Do not use optical instruments to view the laser output. The use of optical instruments to view laser output increases eye hazard. Use only UL/CSA, IEC/EN60825-1/-2 recognized pluggable modules.

**Avertissement:** Ne pas utiliser d'instruments optiques pour voir la sortie du laser. L'utilisation de instruments optiques pour afficher la sortie laser augmente les risques oculaires. Utilisez uniquement UL/CSA, IEC/EN60825-1 /-2 reconnu modules enfichables.



### Warning:

The equipment should only be used within a restricted access area.

The equipment should only be operated by skilled or instructed persons.

The equipment and its modules should only be repaired, maintained or replaced by skilled personnel.

Instructed person is a term applied to persons who have been instructed and trained by a skilled person, or who is supervised by a skilled person.



<電源コードセットに関する使用上の注意事項>

付属の「AC電源コードセット」は、本製品専用のもので、他の電気機器には絶対に使用しないでください。

**Federal Communications Commission (FCC) Notice**

This device complies with Part 15 of FCC rules. Operation is subject to the following two conditions: (1) this device may not cause harmful interference, and (2) this device must accept any interference received, including interference that may cause undesired operation.



**Note**

This equipment has been tested and found to comply with the limits for a class A digital device, pursuant to Part 15 of the FCC rules. These limits are designed to provide reasonable protection against harmful interference when the equipment is operated in a commercial environment. This equipment uses, generates, and can radiate radio frequency energy and if not installed in accordance with the operator’s manual, may cause harmful interference to radio communications. Operation of this equipment in a residential area is likely to cause interference in which case the user will be required to correct the interference at his own expense.

**Class A ITE Notice**



**Warning**

This equipment is compliant with Class A of CISPR 32. In a residential environment this equipment may cause radio interference.



**Warning**

This equipment must be grounded. Do not defeat the ground conductor or operate the equipment without correctly grounding the equipment. If there is any uncertainty about the integrity of the equipment's grounding, please contact the electrical inspection authority or a certified electrician.

**Industry Canada Notice**

**CAN ICES-003 (A)/NMB-003(A)**

This digital apparatus does not exceed the class A limits for radio noise emissions from digital apparatus set out in the Radio Interference Regulations of the Canadian Department of Communications.

Le présent appareil numérique n’émet pas de bruits radioélectriques dépassant les limites applicables aux appareils numériques de la class A prescrites dans le Règlement sur le brouillage radioélectrique édicté par le ministère des Communications du Canada

**VCCI Notice**

This is Class A equipment. Operation of this equipment in a residential environment could cause radio interference. In such a case, the user may be required to take corrective actions.

---

この装置は、クラスA機器です。この装置を住宅環境で使用すると電波妨害を引き起こすことがあります。この場合には使用者が適切な対策を講ずるよう要求されることがあります。 VCCI - A

警告使用者:  
為避免電磁干擾,本產品不應安裝或使用於住宅環境。

此为A级产品，在生活环境中，该产品可能会造成无线电干扰。

在这种情况下，可能需要用户对干扰采取切实可行的措施。

---

### Installation location

The device should be installed only in a server room or computer room where access is:

- Restricted to qualified service personnel or users familiar with restrictions applied to the location, reasons therefore, and any precautions required.
- Only afforded by the use of a tool or lock and key, or other means of security, and controlled by the authority responsible for the location.

Suitable for installation in Information Technology Rooms in accordance with Article 645 of the National Electrical Code and NFPA 75.

---

The logo for ufiSpace, featuring the word 'ufiSpace' in a bold, white, sans-serif font. The 'i' in 'ufi' has a dot, and the 'S' in 'Space' is capitalized. The logo is centered on a dark red, trapezoidal background that is part of a larger graphic design with geometric shapes and a gradient.

**Unifying Cloud & Carrier Networks**

[www.ufispace.com](http://www.ufispace.com)