



S6301-56STP

L2/L3 PoE Switch

Hardware Installation Guide

R1.8





Table of Contents

1	Overview	1
2	Preparation	2
2.1	Installation Tools	2
2.2	Installation Environment Requirements	3
2.3	Preparation Check List.....	5
3	Package Contents	5
3.1	Accessory List	5
3.2	Component Physical Information.....	6
4	Identifying Your System	7
4.1	S6301-56STP System Overview	7
4.2	AC Version PSU Overview.....	7
4.3	Fan Overview	8
4.4	Port Overview.....	8
5	Rack Mounting	10
6	Installing Fan Modules	12
7	Installing Power Supply Units	13
8	Grounding the Switch	15
9	Connecting Power	17
9.1	AC PSU	17
10	Verifying System Operation	18
10.1	Front Panel LED	18
10.2	PSU FRU LED	19
10.3	Fan FRU LED.....	19
10.4	Management Port LED	19
11	Initial System Setup	21
12	Cable Connections	22
12.1	Connecting the USB Cable.....	22
12.2	Connecting the OOB Management Cables.....	22
12.3	Connecting the Transceivers	23
13	Cautions and Regulatory Compliance Statements	24



1 Overview

The UfiSpace S6301-56STP is a high-performance L2/L3 PoE switch designed to meet the growing demands of enterprise and campus access connectivity, with full Power over Ethernet (PoE) support.

Featuring 48 x 1G RJ-45 ports and 8 x 10G SFP+ ports, the S6301-56STP utilizes Broadcom's Trident3-X2 silicon, delivering a switching capacity of 130 Gbps. It fully supports IEEE 802.3af/802.3at on all 48 RJ-45 ports, providing up to 30W of power on each port, ensuring seamless integration of powered devices and robust management capabilities.

Powered by an Intel Denverton 4-core processor, the S6301-56STP simplifies and enhances enterprise and campus networks with flexibility and performance. It also includes redundant, hot-swappable components, offering increased reliability, availability, and reduced maintenance costs.

This document describes the hardware installation process for S6301-56STP.



2 Preparation

2.1 Installation Tools



Screwdriver (Phillips head #2)

Phillips #2 Screwdriver

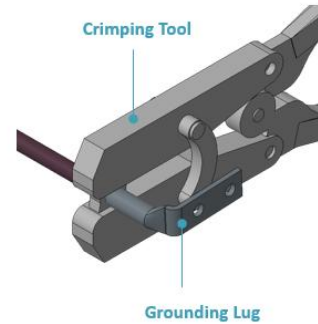

Crimping tool

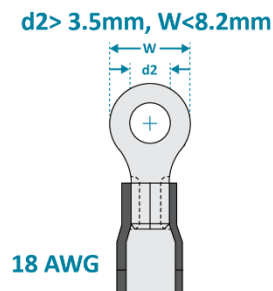

18 AWG wire with ring terminal for DC power supply

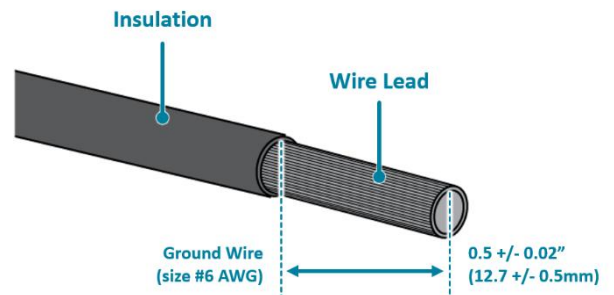

6-AWG wire for grounding



Wire-stripping tools for stripping 6-AWG copper wire

- PC with terminal emulation software. Refer to the "Initial System Setup" section for details.
 - Baud rate: 115200 bps
 - Data bits: 8
 - Parity: None
 - Stop bits: 1
 - Flow control: None

2.2 Installation Environment Requirements

- Power Reserve: The S6301-56STP power supply is available with:
 1. **AC Version:** 1+1 active-active 100 to 240V AC power supply field replaceable unit.

To ensure the active-active feed power design functions properly, a field with dual power circuit is recommend with a reserve of at least 920 watts on each power circuit. Additionally, ensure careful planning of the PoE port configuration to stay within the 820-watt power budget, with 802.3at mode at 30W per port and 802.3af mode at 15.4W per port, to maintain optimal performance and system redundancy.
- Space Clearance: The S6301-56STP width is 17.32 inches (44.0cm) and shipped with a rack mount brackets suitable for 19 inch (48.3cm) wide racks. The depth of the S6301-56STP chassis is 17.32 inches (44cm) without the field replaceable units (FRUs) and comes with adjustable mounting rails suitable for rack depths of 22 inches (55.9cm) to 33 inches (83.8cm). The handle for the fan units will extend outwards by 1 inch (2.5cm) and the handle for the power supplies will extend outwards by 1.5 inches (3.8cm). Therefore, to accommodate the fan and power supply handles, a minimum space clearance of 6 inches (15.24cm) is needed at the back and front of the S6301-56STP. A total minimum reserve depth of 29.32 inches (74.47 cm) is suggested.

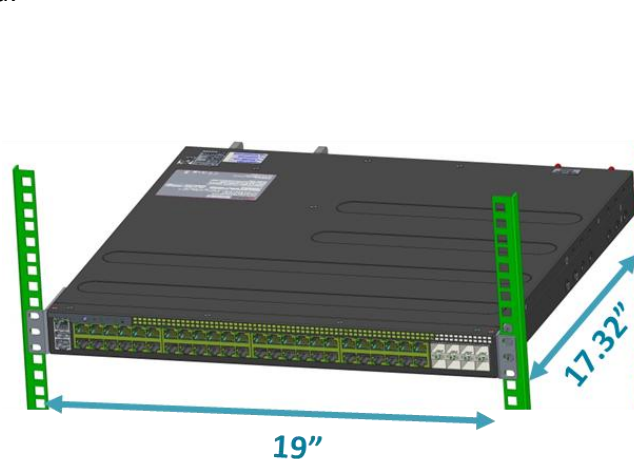

Figure 1.

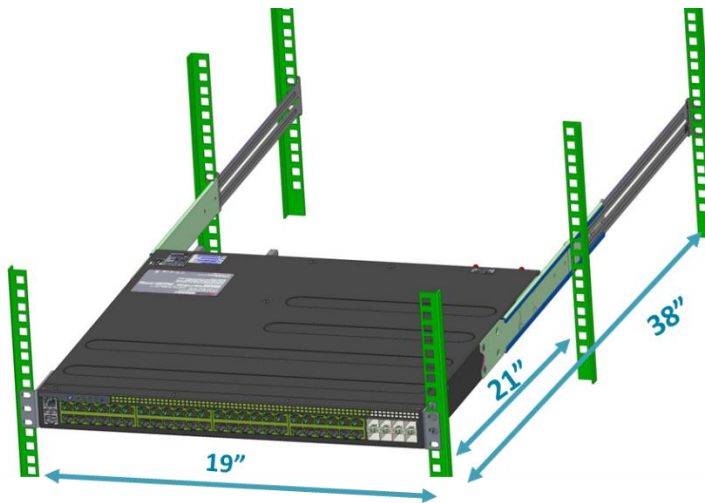

Figure 2.

- Cooling: The S6301-56STP supports front-to-back option (Figure 3.). Make sure the equipment on the same rack have the same airflow direction.

	<p>Note</p>	<p>Ensure all installed fans and power supply units (PSUs) have matching airflow directions (indicated by the same handle color) to maintain proper system operation.</p>
--	--------------------	---

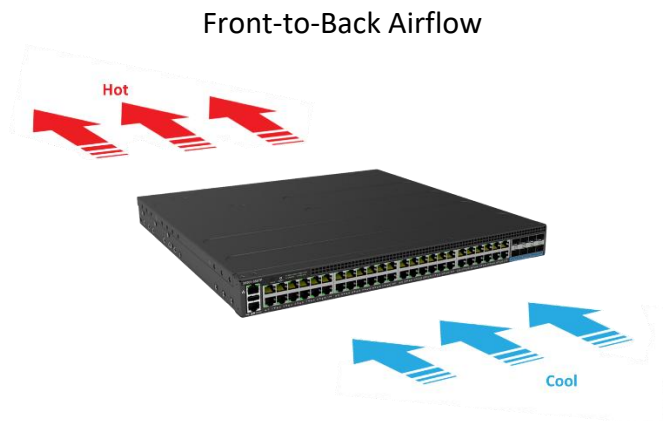

Figure 3.

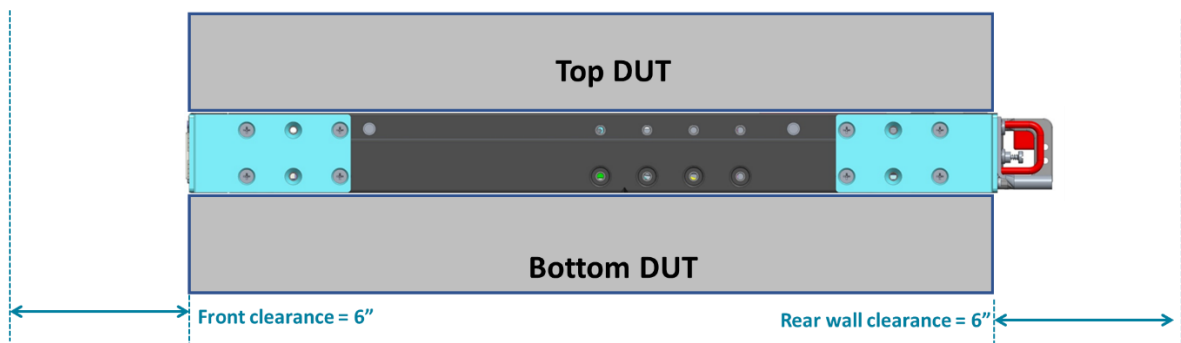

Figure 4.



2.3

Preparation Check List

Task	Check	Date
Power voltage and electric current requirement AC version: 100 to 240V, 12A maximum x2		
Installation spacing requirement: S6301-56STP spacing requires a height of 1RU (1.72"/4.5cm), a width of 19" (48cm) and a depth of 17.32 inches (44cm)		
Thermal requirement S6301-56STP working temperature is 0°C to 45°C (32°F to 113°F)		
Installation tools required #2 Phillips Screwdriver, 6-AWG wire stripper, and crimping tool		
Accessories required PC with terminal emulation software, console cable, 18-AWG wire with ring terminal for power, 6-AWG wire for grounding		

3 Package Contents

3.1 Accessory List

Item	Description	Spec. & Dimensions	Qty.	Weight
1	Grounding Kit for system	1 x Grounding Lug (#6 AWG) 1.14" x 1.47" x 0.49" (29 x 37.5 x 12.5mm) 2 x Screw: M4*L8.0mm 2 x M4 Lock Washers	1 set	0.037lb (17g)/set
2	Rack Mount Bracket	3.46" x 1.69" x 0.79" (19" width rack) (88x 43 x 20mm)	2 pcs	0.37lb (170g)/2pcs (0.19lb (85g)/pcs)
3	Screw Kit (for Rack Mount Bracket)	8 x Screws M4.0*L6.5mm	1 set	0.02lb (7g)/set
4	Adjustable Mounting Rail (for 4 posts)	16.02" x 1.69" x 0.83" (406.8 x 43 x 21mm) (for 22" to 33" rack depth)	2 sets	1.39lb (630g)/2 set (0.69lb (315g)/set)
5	Screw Kit (for Adjustable Mounting Rail)	8 x Screws M4.0*L6.5mm	1 set	0.02lb (7g)/set
6	Power Cord (AC Version only)	78.7" (2000mm)	2 pcs	0.73lb (330g)/2pcs 0.36lb (165g)/pcs

7	USB 3.0 cable	7.87" (200mm)	1 pcs	0.038lb (17.2g)/pcs
8	RJ45 to DB9 Female Cable	95.98" (2438mm)	1 pcs	0.23lb (105g)/pcs

3.2 Component Physical Information

Specification	Item	Description
Weight	Total package contents	25.00lbs (11.34kg)
	Chassis without FRU	12.65lbs (5.74kg)
	Power Supply Unit (PSU)	AC PSU: 1.8 lbs (0.82kg)
	Fan module unit	0.19lbs (90g)
	Grounding lug kit	0.037lbs (17g)
	Adjustable mounting rail	0.69lbs (315g)
	USB 3.0 cable	0.04lbs (17.2g)
	AC power cord (AC version only)	0.36lbs (165g)
	RJ45 to DB9 female cable	0.23lbs (105g)
Dimension	S6301-56STP (W x D x H)	17.32" x 17.32" x 1.72" (440 x 440 x 43.8mm)
	PSU (W x D x H)	2.87" x 7.28" x 1.57" (73 x 185 x 40mm)
	Fan module (W x D x H)	2.03" x 1.66" x 2.28" (51.5 x 42.2 x 57.8mm)



4 Identifying Your System

4.1 S6301-56STP System Overview

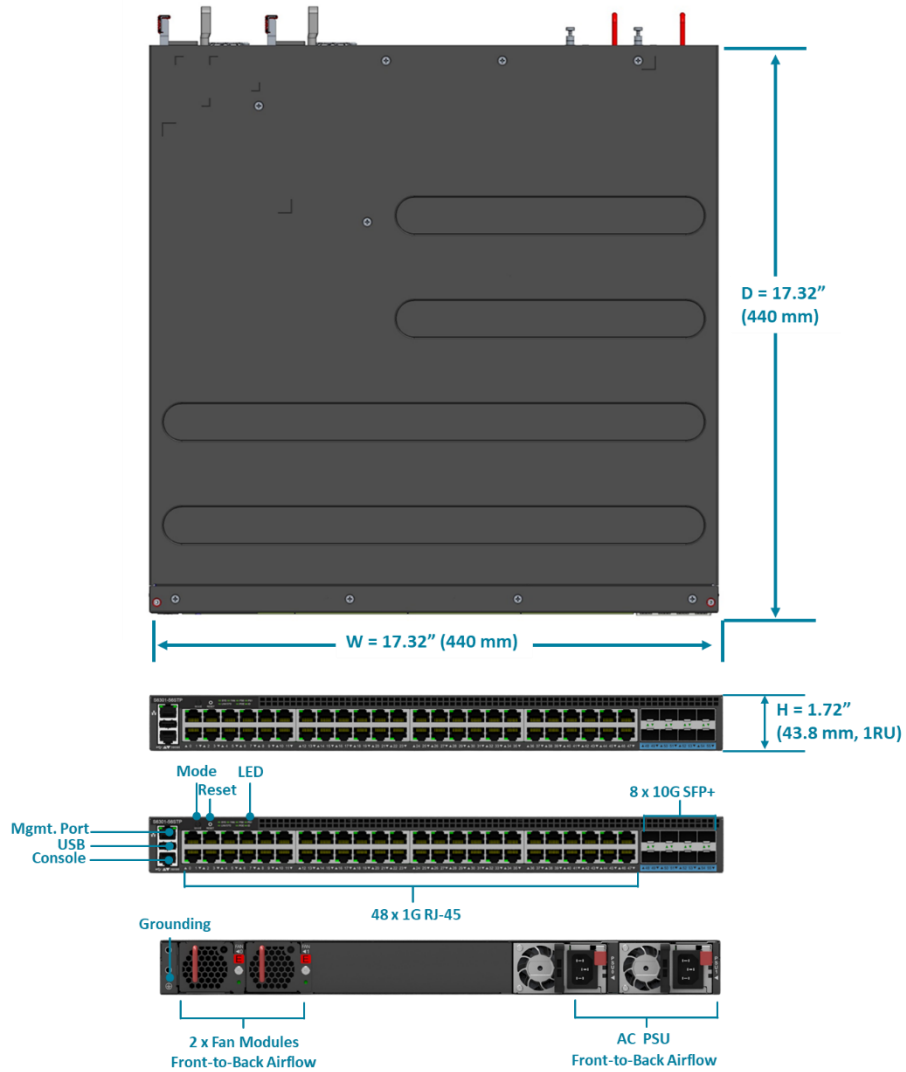

Figure 5.

4.2 AC Version PSU Overview

1+1, hot swappable power supply unit (PSU) field replaceable unit (FRU) supporting front-to-back airflow. Figure 8 is the outlook and the detail dimension data.



Note

Ensure careful planning of the PoE port configuration to stay within the 820-watt power budget, with 802.3at mode at 30W per port and 802.3af mode at 15.4W per port, to maintain optimal performance and system redundancy.

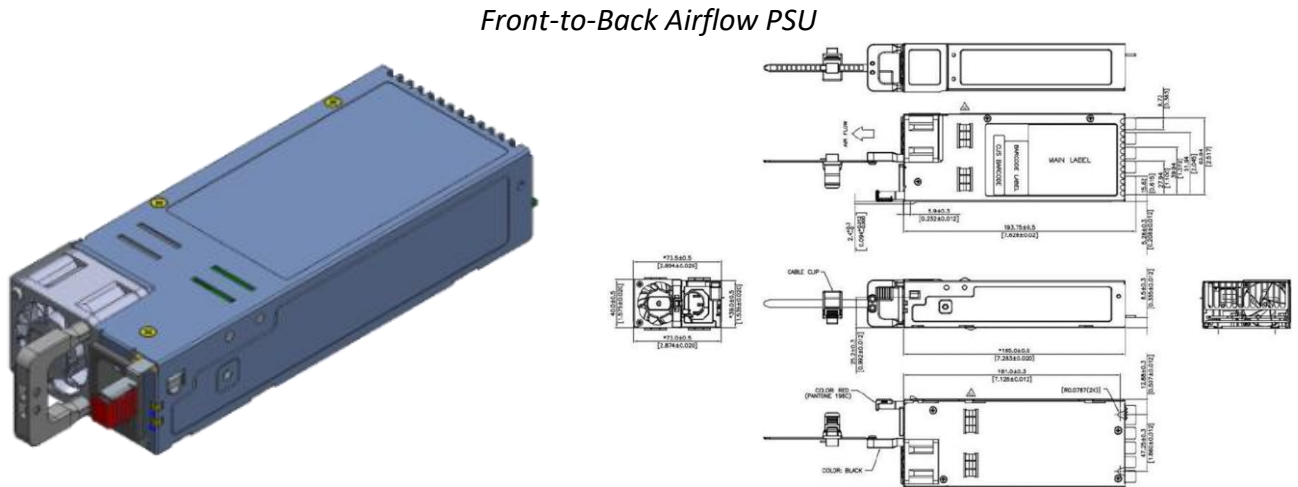

Figure 6.

4.3 Fan Overview

1+1, hot swappable fan field replaceable unit (FRU).



Note

Ensure all installed fans and power supply units (PSUs) have matching airflow directions (indicated by the same handle color) to maintain proper system operation.



(Front-to-Back Airflow Fans)

Figure 7.

4.4 Port Overview

Port ID	Form Factor	Maximum Support Distance	Support Speed
0 ~ 47	RJ45	100m (328ft)	10M/100M/1G
48~55	SFP+	80km(49.7mi)	1G/10G

Port 0 to 47 support Power over Ethernet (PoE), are compliant with IEEE 802.3af/802.3at, and provide up to 30W per port.

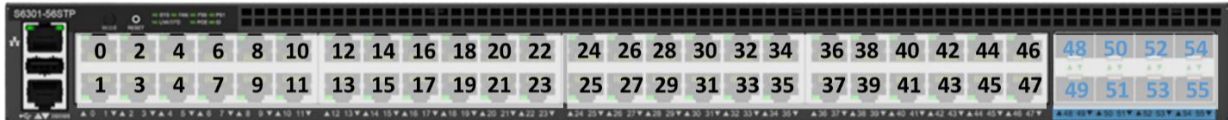

Figure 8.



5 Rack Mounting



Caution

It is recommended that installation be done by two trained professionals. One individual should hold the equipment in position on the rack while the other secures it in place.



Note

Illustrations are for reference purposes only. Actual equipment and scenario may differ. Screws for rack posts not included.

1. Secure the rack mount brackets onto the switch.
Align the rack mount brackets with the holes provided on the both sides of the case and secure the brackets using the 8 M4.0*L6.5mm screws provided with the package.



Figure 9.

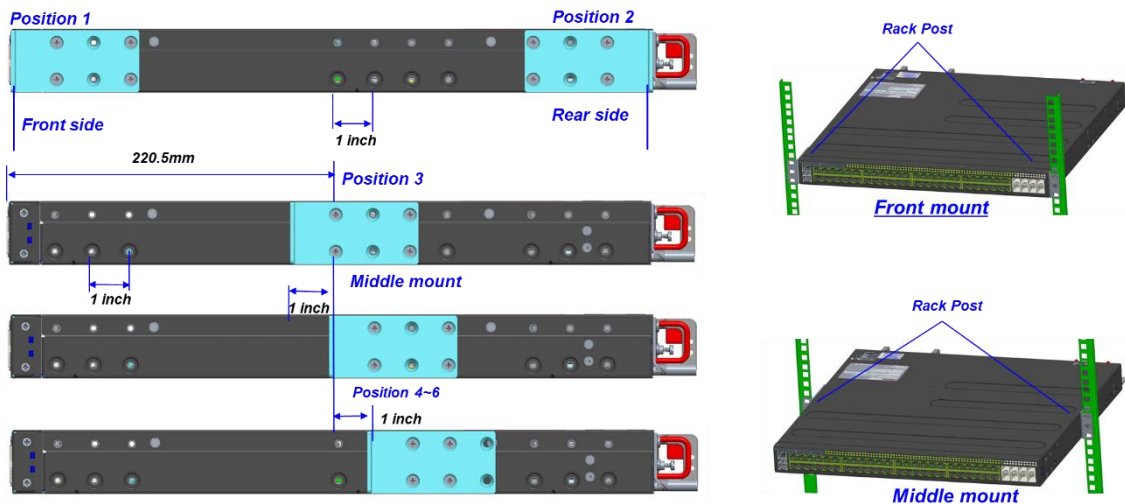

Figure 10.

2. Secure the switch onto the rack posts.
Mark the location on both posts to ensure it is leveled before securing the switch onto the rack. (See Figure Below).



Figure 11.

For a 4 post rack, first secure the adjustable mounting rail to the back of the switch using the M4.0*L6.5mm screws provided in the package. Then secure the adjustable mounting rail to the rack posts. (See Figure Below).

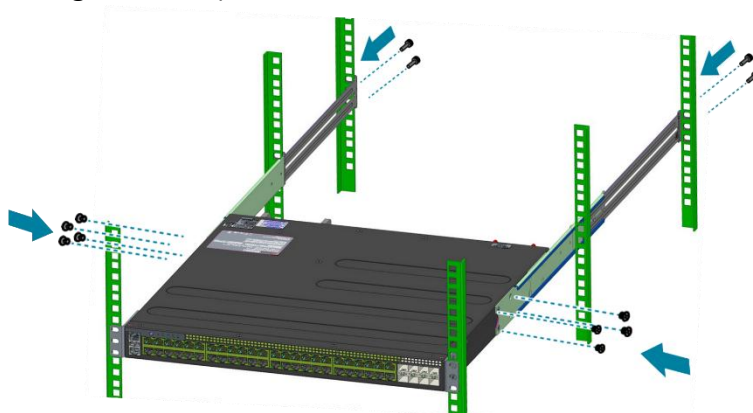

Figure 12.



6 Installing Fan Modules

The fan modules are hot swappable field replaceable units (FRUs), which can be replaced while the switch is operating as long as all the remaining modules are installed and in operation. The fans come pre-installed and the following steps are instructions on how to install a new fan module.

1. Loosen the captive screw located on the fan module.



Figure 13.

2. Grip the fan's handle and firmly pull it out of the fan bay.

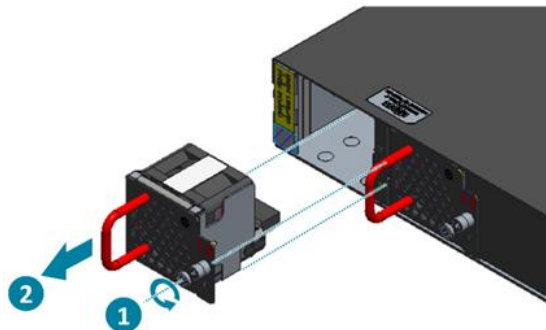

Figure 14.

3. Align the new fan module with the fan bay.
4. Carefully slide the new fan module into the fan bay and gently push until it is flush with the case.
5. Secure the captive screw on the fan module to lock the fan in place.

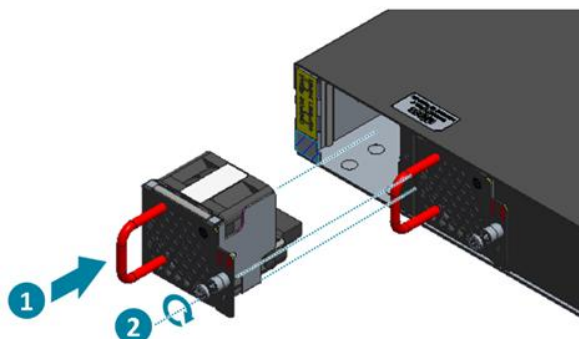

Figure 15.



7 Installing Power Supply Units

The power supply unit (PSU) is a hot swappable field replaceable unit (FRU) and can be replaced while the switch is operating as long as the remaining (second) PSU is installed and in operation, and under a maximum of 820-watt power budget allocated for IEEE 802.3at(30W) & IEEE802.3af(15.4W) PoE ports. This setup ensures the system maintains redundancy during PSU maintenance or replacement.

The PSUs come pre-installed and the following are instructions on how to install a new PSU. The process for removing and installing the PSUs are the same for all models.

AC version PSU

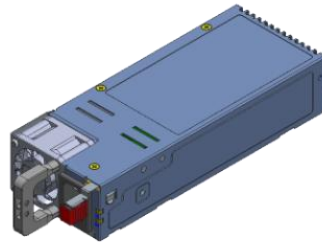

Figure 16.



Caution

Shock hazard!

For safety, please disconnect all power inputs from the power supply unit before servicing the switch.

1. Locate the release tab on the PSU. Then press and hold down the release tab to unlock the PSU from the power bay.
2. While holding down the release tab, grip the PSU's handle and firmly pull it out of the power bay.

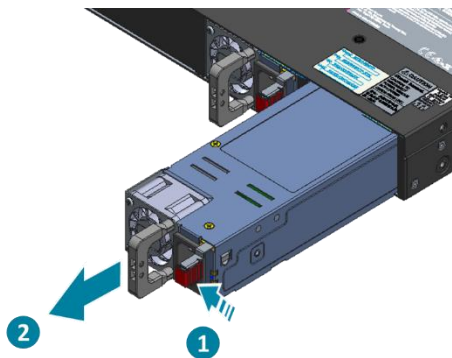

Figure 17.

3. Align the new PSU with the power bay, ensuring the PSU's power connector is in the correct

position.

4. Carefully slide the new PSU into the power bay and gently push until it is flush with the case.
5. An audible click will be heard when the PSU is installed correctly. The PSU will not go in all the way if it is in the wrong direction.



Note

Illustrations are for reference purposes only. Actual PSU position may differ.

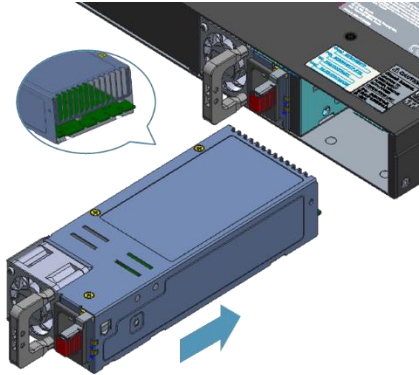

Figure 18.



8 Grounding the Switch

It is recommended that equipment changes be done on a grounded rack system. This will reduce or prevent the risk of shock hazards, equipment damage, and potential of data corruption.

The switch can be grounded from the switch's case and the power supply units (PSUs). When grounding the PSUs, ensure that both PSUs are grounded at the same time in case one of them is removed. A grounding lug and M4 screws and washers are provided with the package contents, however, the grounding wire is not included. For convenience, there are two locations on the case in which the grounding lug may be fixed.

The following instructions are for grounding the switch.



This equipment must be grounded. Do not defeat the ground conductor or operate the equipment without correctly grounding the equipment. If there is any uncertainty about the integrity of the equipment's grounding, please contact the electrical inspection authority or a certified electrician.

1. Before grounding the switch, ensure that the rack is properly grounded and in compliance with local regulatory guidelines. Ensure that there is nothing that can obstruct the connection for grounding and remove any paint or materials that may prevent good grounding contact.
2. Strip the insulation from a size #6 AWG grounding wire (not provided within the package contents), leaving $0.5'' \pm 0.02''$ ($12.7\text{mm} \pm 0.5\text{mm}$) of exposed grounding wire.
3. Insert the exposed grounding wire all the way into the hole of the grounding lug (provided with package contents).
4. Using a crimping tool, firmly secure the grounding wire to the grounding lug.

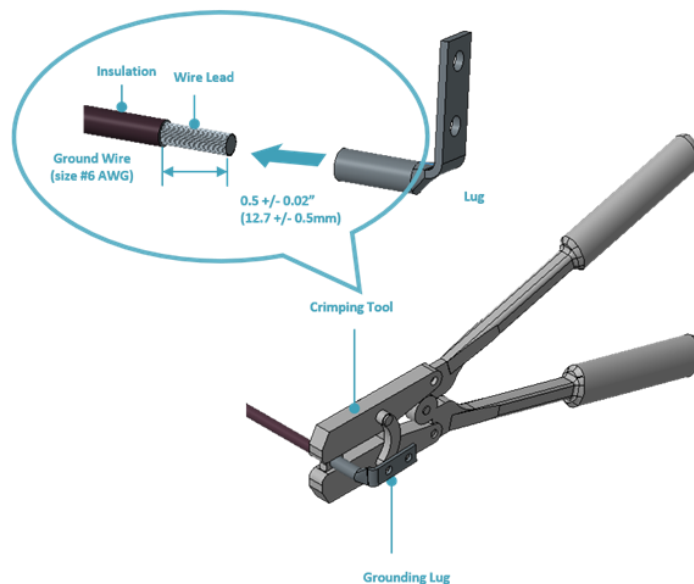

Figure 19.

5. Locate the designated location for securing the grounding lug, which is located on the side of S6301-56STP Hardware Installation Guide | 15

the switch and remove the protective label.

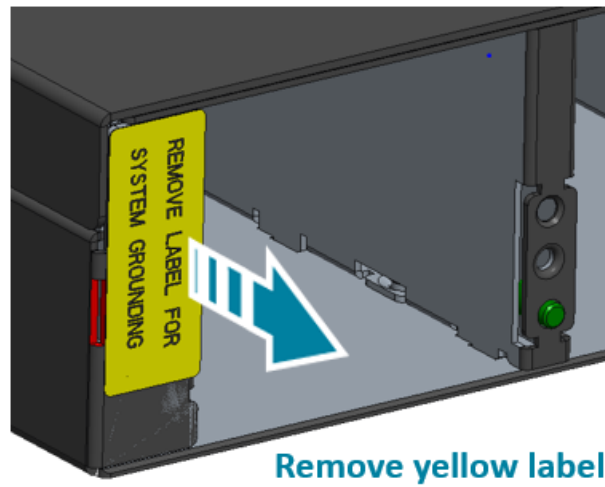

Figure 20.

- Using 2 M4 screws and 2 washers (provided with the package contents), firmly lock the grounding lug to either of the designated grounding locations on the switch.

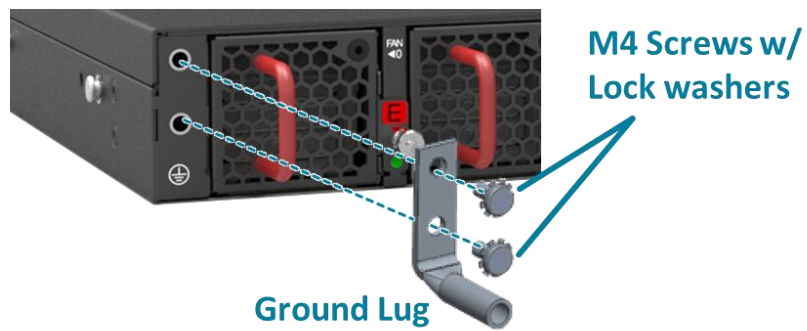

Figure 21.



9 Connecting Power



Note

All power cables must be routed entirely within the designated rack cable management areas and fixed properly using appropriate strain relief and fasteners.

9.1 AC PSU

1. Ensure there is enough power to supply the system.

The maximum system power consumption is 145 watts without PoE enabled, and 1517 watts with PoE enabled, when using an input voltage of 100-240VAC. It is recommended to ensure that enough power is reserved from the power distribution system before installation. Also, please ensure that both PSUs have been properly installed before powering up the equipment. To maintain optimal redundancy, please ensure that the PoE ports use a maximum of 820 watts of power, with each port operating in 802.3at mode at 30W or in 802.3af mode at 15.4W.



Note

Testing criteria for maximum power are as follows:

Temperature: 45°C

Optics: full populated

Traffic: 100% load

2. Attach the power cable.

Locate the AC inlet connector on the PSU and plug the AC power cable (125VAC 13A, IEC60320 C13) into the AC inlet connector.

3. Feed AC power into the system.

Use a 100V to 240V AC power source rated for operation up to 5000 meters, and be aware that the system will receive 54.5V power instantly upon connection.

The PSU has a built-in 12.5A, fast acting fuse based on the PSU maximum capacity, which will act as a second-tier system protection in case the power distribution unit's fuse is not functioning.

4. Verify that the power supply is operating.

If connected correctly, when turned on, the LED on the PSU will light up with a Green color designating normal operation.

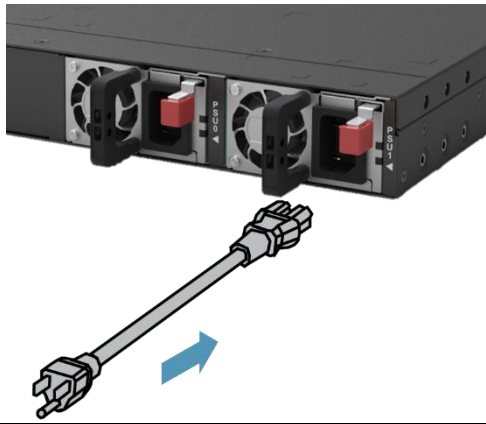

Figure 22.

10 Verifying System Operation

10.1 Front Panel LED

Verify basic operations by checking the system LEDs located on the front panel. When operating normally, the SYS, FAN, and PSU LEDs should all display green.



Figure 23.

LED Condition	Equipment Status
SYS	
Off	No power
Solid Green	Host CPU/BMC boot complete
Blinking Green	System is booting
Solid Yellow	DIAG OS boot complete
FAN	
Off	Fans are not initialized
Solid Green	All Fans are work normal
Blinking Yellow	Fan fail: one or more Fans need service
PSU	
Solid Green	PSU0 working normal
Blinking Yellow	PSU0 fail (PSU0 needs service)

PS1	
Solid Green	PSU1 working normal
Blinking Yellow	PSU1 fail (PSU1 needs service)
ID	
Off	No Power
Blinking Blue	Beacon feature is enabled on the switch
LNK/SPD	
Off	POE mode
Solid Green	LED on each network port indicates the link & speed status
POE	
Off	Link/Speed mode
Solid Green	LED on each network port indicates the PoE status
* The Mode button on the front panel allows switching between LNK/SPD and PoE status LEDs	

10.2 PSU FRU LED

Additional information about PSU status can be obtained by the LEDs located on the PSU itself.

LED Condition	Equipment Status
Off	No input power to all power supplies.
Green	Output ON and OK
Blinking Green	PSU standby state input power present
Blinking Green	Power supply firmware updating (Boot-loader mode).
Yellow	Power supply critical event causing a shutdown, failure, over current, short circuit, over voltage, fan failure, and/or over temperature.
Blinking Yellow	AC power cord unplugged or AC power lost with a second power supply in parallel still with AC input power.
Blinking between Green and Yellow	Power supply warning events where the power supply continues to operate; high temp, high power, high current, and/or slow fan.

10.3 Fan FRU LED

LED Condition	Equipment Status
Off	No input power
Solid Green	Fan is functioning normal
Blinking Amber	Fan is abnormal, service is required

10.4 Management Port LED

LED Condition	Equipment Status
Left LED	

Off	No power
Solid Green	1G link-up
Blinking Green	1G TX/RX activity
Right LED	
Off	No power
Solid Amber	10M/100M link-up
Blinking Amber	10M/100M TX/RX activity



11 Initial System Setup

Establishing a first-time serial connection.

To assign an IP address, you must have access to the command line interface (CLI). The CLI is a text-based interface that can be accessed through a direct serial connection to the device.

Access the CLI by connecting to the console port. After you assign an IP address, you can access the system through Telnet or SSH by Putty, TeraTerm or HyperTerminal.

Perform the following steps to access the device through a serial connection:

1. Connect the console cable.
 - The console can be connected using the RJ45 port labelled IOIO.
 - To connect to console, plug a RJ45 serial cable into the console port and connect the other end to the computer. Cable types may vary depending on the model.

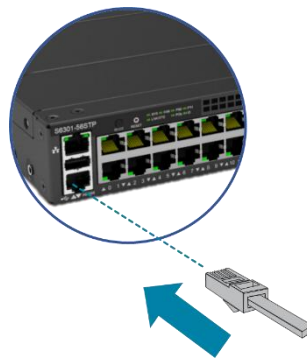

Figure 24.

2. Check for serial control availability.
Disable any serial communication programs running on the computer such as synchronization programs to prevent interference.
3. Launch a terminal emulator.
Open a terminal emulator application such as HyperTerminal (Windows PC), Putty or TeraTerm and configure the application. The following settings are for a Windows environment (other operating systems will vary):
 - Baud rate: 115200 bps
 - Data bits: 8
 - Parity: None
 - Stop bits: 1
 - Flow control: None
4. Login to the device.
After the connection is established, a prompt for the username and password displays. Enter the username and password to access the CLI. The username and password should be provided by the Network Operating System (NOS) vendor.



12 Cable Connections

12.1 Connecting the USB Cable

Connect the USB 2.0 A Type plug (male connector) into the USB port (female connector) located on the front panel of the switch.

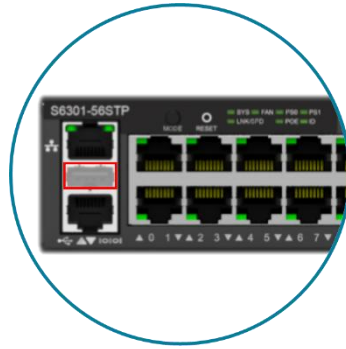



Figure 25.

12.2 Connecting the OOB Management Cables



Note

We recommend that you use a Category 5 (Cat 5e) cable for the OOB management.

Connect the OOB management cable by locating the RJ45 OOB port marked a  symbol.

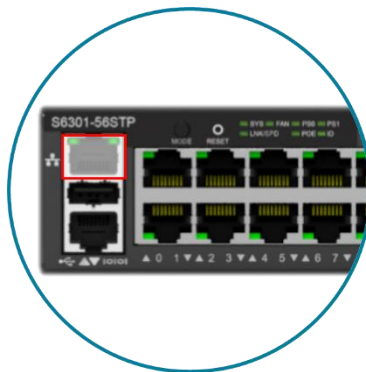

Figure 26.

12.3 Connecting the Transceivers



Note

To prevent over tightening and damaging the optic fibers, it is not recommended to use tie wraps with optical cables.

Read the following guidelines before connecting the transceiver:

- Before installing the switch, take into consideration rack space requirements for cable management and plan accordingly.
- It is recommended to use hook-and-loop style straps to secure and organize the cables.
- For easier management, label each fiber-optic cable and record its respective connection.
- Maintain a clear line of sight to the port LEDs by routing the cables away from the LEDs.



Caution

Before connecting anything (cables, transceivers, etc.) to the switch, please ensure to discharge any static electricity that may have built up during handling. It is also recommended the cabling be done by a professional who is grounded, such as by wearing an ESD wrist strap.

Please follow the steps below for connecting a transceiver.

1. Remove the new transceiver from its protective packaging.
2. Remove the protective plug from the transceiver port.
3. Place the bail (wire handle) in the unlocked position and align the transceiver with the port.
4. Slide the transceiver into the port and use gentle pressure to secure it in place. An audible click can be heard when the transceiver is secured in the port.



13

Cautions and Regulatory Compliance Statements



Safety Notices

Caution! Shock hazard!

TO DISCONNECT POWER, REMOVE ALL POWER CORDS FROM UNIT.



Electrical Hazard: Only qualified personnel should perform installation procedures.
Risques d'électrocution: Seul un personnel qualifié doit effectuer les procédures d'installation.



Warning: Network Switch power supplies do not have switches for turning the unit on and off. Before servicing, disconnect all power cords to remove power from the device. Make sure that these connections are easily accessible.

Avertissement: Network Switch alimentations ne sont pas des interrupteurs pour allumer l'appareil et en dehors. Avant l'entretien, débranchez tous les cordons d'alimentation pour couper l'alimentation de l'appareil. Assurez-vous que ces connexions sont facilement accessibles.



Caution: Before mounting the device, ensure that the rack can support it without compromising stability. Otherwise, personal injury and/or equipment damage may result.



Caution: Use of controls or adjustments or performance of procedures other than those specified herein may result in hazardous radiation exposure.



Caution: Only Laser Class 1 optical transceivers shall be used.



Warning: Do not use optical instruments to view the laser output. The use of optical instruments to view laser output increases eye hazard. Use only UL/CSA, IEC/EN60825-1/-2 recognized pluggable modules.

Avertissement: Ne pas utiliser d'instruments optiques pour voir la sortie du laser. L'utilisation de instruments optiques pour afficher la sortie laser augmente les risques oculaires. Utilisez uniquement UL/CSA, IEC/EN60825-1 /-2 reconnu modules enfichables.



Warning:

The equipment should only be used within a restricted access area.

The equipment should only be operated by skilled or instructed persons.

The equipment and its modules should only be repaired, maintained or replaced by skilled personnel.

Instructed person is a term applied to persons who have been instructed and trained by a skilled person, or who is supervised by a skilled person.



<電源コードセットに関する使用上の注意事項>

付属の「AC電源コードセット」は、本製品専用のもので、他の電気機器には絶対に使用しないでください。

**Warning:**

The product is considered not likely to require connection to an Ethernet network with outside plant routing.

Class A ITE Notice

This equipment is compliant with Class A of CISPR 32. In a residential environment this equipment may cause radio interference.

VCCI Notice

This is Class A equipment. Operation of this equipment in a residential environment could cause radio interference. In such a case, the user may be required to take corrective actions.

この装置は、クラスA機器です。この装置を住宅環境で使用すると電波妨害を引き起こすことがあります。この場合には使用者が適切な対策を講ずるよう要求される場合があります。

VCCI-A

警告使用者:
為避免電磁干擾,本產品不應安裝或使用於住宅環境。

此为A级产品，在生活环境中，该产品可能会造成无线电干扰。
在这种情况下，可能需要用户对干扰采取切实可行的措施。

The logo for ufiSpace, featuring the word 'ufiSpace' in a bold, white, sans-serif font. The 'i' in 'ufi' has a dot, and the 'S' in 'Space' is capitalized. The logo is centered on a dark red, trapezoidal background that is part of a larger graphic design with geometric shapes and a gradient.

Unifying Cloud & Carrier Networks

www.ufispace.com